

SHINANO INC.

GENERAL CATALOG

2022-2024 Vol.1

 PNEUMATIC TOOLS
SHINANO INC.
MADE IN JAPAN

 YouTube

shinanoinc.com





SHINANO_AIRTOOLS



JQA-QMA13047



MS
CM009



JQA-QMA13047



091

AIR TOOLS 2022-2024 Vol.1 CATALOG

- IMPACT WRENCHES ■ DRIVERS ■ RATCHET WRENCHES
- SANDERS ■ POLISHERS ■ GRINDERS ■ DRILLS/SPOTMILLS
- CUTTING TOOLS ■ OTHERS

 PNEUMATIC TOOLS
SHINANO INC.

MADE IN JAPAN

Shinano Inc was established in 1949, specialising in Pneumatic Tools from 1969. Building on our experience, we achieve excellent results in build quality, accuracy and user safety. With more than a hundred tools in the range, Shinano Inc is one of the worlds largest manufacturers of pneumatic tools.

Sophisticated and Functional Design

Our tools are the result of over 50 years of pneumatic tool design. Our experience in research, engineering and production techniques, have created a line of high performance tools that are durable, reliable and easy to use.

Perfection

Our customers needs are our top priority. Performance, quality, noise control and user safety, we stand by our products and strive for excellence.

This is our promise of the SI mark.



The Green Project

Shinano contribute to environmental protection



Solar power generation

The photovoltaics business was started from January, 2013 as an activity which utilizes renewable energy effectively for global environment protection.

We are reducing the CO2 in the same amount as the 20,000 trees in year. Generated the equivalent of 98% of the electricity used in the factory in 2020.



Factory rooftop, SHINANO INC.



Kagoshima Solar Power Plant



Wakayama Solar Power Plant



ISO9001 Management system certificate



JQA-QMA13047



MS CM009



JQA-QMA13047



091

IMPACT WRENCHES

IMPACT WRENCHES 5

1/4" Impact Wrench
SI-1310S 6
SI-1315S 6
SI-1355 6
SI-1365 6
SI-1305 6

3/8" Impact Wrench
SI-1650AH 6
SI-1420T 6
SI-1422T 6



1/2" Impact Wrench
SI-1357 7
SI-1605 7
SI-1605SR 7

3/4" Impact Wrench
SI-1457 7
SI-1610 7
SI-1610SR 7
SI-1455SR 7
SI-1492B 7
SI-1492BSR 7

1 1/2" Impact Wrench
SI-1460 8
SI-1460SR 8
SI-1490B 8
SI-1490BSR 8

1" Impact Wrench
SI-1555SR 9
SI-1860 9
SI-1866 9
SI-1870/SI-1870I 9
SI-1876/SI-1876I 9
SI-1878/SI-1878I 9
SI-1880/SI-1880I 10
SI-1888/SI-1888I 10

1-1/2" Impact Wrench
SI-1900/SI-1900I 10

IMPACT CLUTCHES 10

DRIVERS

DRIVERS 11

Impact Driver
SI-1052 12
SI-1062 12
SI-1060 12
SI-1065 12
SI-1356D 12
SI-1365D 12
SI-1070 13

Screw Driver
SI-1170 13
SI-1140 13
SI-1161 13
SI-1166A 13
SI-1166-8A 13



RATCHET WRENCHES

RATCHET WRENCHES 14

1/4" Ratchet Wrench
SI-1107B 15
SI-1108B 15

3/8" Ratchet Wrench
SI-1217EX 15
SI-1218EX 15

1/2" Ratchet Wrench
SI-1200B 15
SI-1205B 15

3/8" Ratchet Wrench
SI-1251 16
SI-1252 16

1/2" Ratchet Wrench
SI-1340EX 16
SI-1345EX 16
SI-1320A 16

1" Ratchet Wrench
SI-1325A 16
SI-1261 17
SI-1262 17

3/8" Ratchet Wrench
SI-1241A 17
SI-1435 17
SI-1288 17

HEX 17mm Through
SI-1288 17



SANDERS

SANDERS 18

Central Vacuum Dual Action Sander
SI-3121-6 20

Central Vacuum Dual Action Sander
SI-3121/SI-3121M 20

Dual Action Sander
SI-3101LG/SI-3101LGM 20

Self Vacuum Dual Action Sander
SI-3111LG/SI-3111LGM 20

Dual Action Sander
SI-3103B/SI-3103BM 20

Dual Action Sander
SI-3103A/SI-3103AM 21
SI-3103-6A/SI-3103-6AM 21

Self Vacuum Dual Action Sander
SI-3113A/SI-3113AM 21
SI-3113-6A/SI-3113-6AM 21

Dual Action Sander
SI-3101/SI-3101M 21
SI-3101-6/SI-3101-6M 21

Self Vacuum Dual Action Sander
SI-3111/SI-3111M 21
SI-3111-6/SI-3111-6M 21

Self Vacuum Dual Action Sander
SI-3118A/SI-3118AM 22
SI-3118-6A/SI-3118-6AM 22

Self Vacuum Geared Dual Action Sander
SI-3115R/SI-3115R-6 22

Dual Action Sander
SI-3100/SI-3100M 22

Mini Dual Action Sander
SI-3102M 22

Mini Self Vacuum Dual Action Sander
SI-3112M 22

Orbital Sander
SI-3001A/SI-3001AM 23

Self Vacuum Orbital Sander
SI-3011A/SI-3011AM 23

Orbital Sander
SI-3003A/SI-3003AM 23

Orbital Sander
SI-3005 23
SI-3007/SI-3007M 23

Self Vacuum Orbital Sander
SI-3018A/SI-3018AM 24

Orbital Sander
SI-3003B/SI-3003BM 24

Disc Sander
SI-2026 24
SI-2351 24

ACCESSORIES 25-26

Heavy Duty Mini Sander
SI-2008EX 27

Mini Sander
SI-2107A 27

Heavy Duty Mini Sander
SI-2108EX 27
SI-2108EX-2 27

Disc Sander
SI-2210 28

SI-2201 28
SI-2201-2 28
SI-2202 28
SI-2202-2 28

Mini Dual Action Sander
SI-2110S 28

Disc Sander
SI-2300 29

Oscillation Sander
SI-3200A 29

Wet Sander
SI-2322WR-LE 29
SI-2322WR 29

Mini Orbital Finishing Sander
SI-3310 30

ACCESSORIES 30
SANDER LINEUP 31
Sanding Mechanism 31



SANDERS 18

Belt Sander
SI-2740 19
SI-2741 19
SI-2700 19
SI-2700L 19
SI-2700LS 19
SI-2800 19
SI-2830 19

POLISHERS

POLISHERS 32

Geared Dual Action Polisher
SI-2415 33

Dual Action Polisher
SI-3100P 33

Single Action Polisher
SI-2221 33
SI-2224S 33
SI-2009EX 34
SI-2009H 34
SI-2400 34

Light Sander Polisher
SI-2405 34

Single Action Polisher
SI-2451 34

ACCESSORIES 34



DRILLS / SPOT MILLS

DRILLS / SPOT MILLS 41

Drill
SI-5305-8A 42
SI-5501 43
SI-5506 43

Reversible Drill
SI-5355 43

Angle Head Drill
SI-5405 43
SI-5405-6 43

Reversible Drill
SI-5500 43

Drill
SI-2015AD 42
SI-5100A 42
SI-5200A 42
SI-5300A 42

Reversible Drill
SI-5305A 42

Spot Mill
SI-5800 44
SI-5850 44

ACCESSORIES 44



INDUSTRIAL TOOLS

INDUSTRIAL TOOLS 57-68

DISC GRINDERS 57-62
STRAIGHT GRINDERS 63
DUAL ACTION SANDER 64
DIE GRINDERS 65-66
EDGE CUTTER 67-68



ACCESSORIES

SOUND & VIBRATION

MAINTENANCE CHECK

QUALITY

GRINDERS

GRINDERS 35

Die Grinder
SI-2015A 36
SI-2015A-6 36
SI-2010 36
SI-2010-6 36
SI-2005HD 37
SI-2005HD-6 37
SI-2006S 37
SI-2006S-6 37

Cut off Grinder
SI-2033 37

Die Grinder
SI-2022S 37
SI-2022S-6 37
SI-2023 37
SI-2023-6 37

Disc Grinder
SI-2501L 38
SI-2501 38
SI-2500L 38
SI-2500 38
SI-2515LA 38
SI-2505L 38

Wet Grinder
SI-2515WE 39

Disc Grinder
SI-2520L 39
SI-2600L 39

Micro Grinder
SI-2050AG 40
SI-2051SG 40
ACCESSORIES 40



CUTTING TOOLS

CUTTING TOOLS 45

Saw
SI-4700B 46
SI-4730 46

Saw
SI-4710 47
SI-4710F 47

Saw & File
SI-4740 47
SI-4740F 47

Nibbler
SI-4600 48

Shear
SI-4500 48

Trimmer
SI-2018A 48
SI-2018A-6 48

Oscillation Cutter
SI-4300 48
ACCESSORIES 49



OTHERS

OTHERS 50

Air Hammer
SI-4120A 51
SI-4120AH 51
AIR HAMMER 51
ACCESSORIES 51

Needle Scaler
SI-4160 52
SI-4150EX 52

Hydro Puncher
SI-4800 52



Viewpoint of the catalogue page

Viewpoint of the product page

Model Number: **SI-1365** 3/8" Impact Wrench

Descriptions:

- The ultimate design for a 3/8" sq drive impact wrench
- Precision machined air motor for durability Muffled exhaust for industrial use

Impact Clutch: Double Hammer

Attachment Included: 458-58 Maximum Torque: 100Nm

Maximum Torque: 100Nm

Product image: [Image of SI-1365 impact wrench]

Figure of dimensions: [Image showing dimensions of SI-1365 impact wrench]

Specification:

- Maximum Torque Nm/(ft-lb): 100/(74)
- Working Torque Range Nm/(ft-lb): 0.80/(0.59)
- Bolt Cap mm/(in): 10/(3/8)
- Free Speed r.p.m.: 8,000
- Weight kg/(lb): 1.31/(2.89)
- Noise Level dBA/(power): 91/(102)
- Vibration a/k m/s²: 8.3/1.3
- Max Air Consumption CFM/(L/S): 19.8/(9.3)
- Avg Air Consumption CFM/(L/S): 3.3/(1.6)
- Air Inlet Size in.: 1/4
- Hose Size mm/(in): 10/(3/8)



SI-1490BSR

IMPACT WRENCHES

- 1/4" IMPACT WRENCHES
- 3/8" IMPACT WRENCHES
- 1/2" IMPACT WRENCHES
- 3/4" IMPACT WRENCHES
- 1" IMPACT WRENCHES
- 1-1/2" IMPACT WRENCH

IMPACT WRENCHES

1/2" Impact Wrenches · 1/4" Impact Wrench · 3/8" Impact Wrenches

SI-1310S

1/4" Impact Wrench

- Composite body absorbs the vibration remarkably well and also protects your hand from the cold.
- Compact, lightweight, and a "feather touch" trigger for easy operation.
- Rear exhaust from handle-end directs air away from operator and workplace.

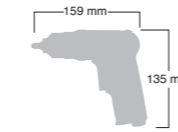
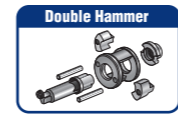

SI-1310S
Maximum Torque :
40Nm

SI-1315S

3/8" Impact Wrench



SI-1315S
Maximum Torque :
60Nm

	SI-1310S	SI-1315S
Maximum Torque Nm/(ft-lb)	40/(30)	60/(44)
Working Torque Range Nm/(ft-lb)	0-35/(0-26)	0-50/(0-37)
Bolt Cap mm/(in.)	8/(5/16)	10/(3/8)
Free Speed r.p.m.	10,000	10,000
Weight kg/(lb)	0.63/(1.39)	0.63/(1.39)
Noise Level dBA/(power)	86/(97)	86/(97)
Vibration a/k m/s ²	4.8/0.9	4.9/1.0
Max Air Consumption CFM/(L/S)	12.6/(5.9)	12.6/(5.9)
Avg Air Consumption CFM/(L/S)	2.1/(1.0)	2.1/(1.0)
Air Inlet Size in.	1/4	1/4
Hose Size mm/(in.)	10/(3/8)	10/(3/8)

SI-1355

3/8" Impact Wrench

- Standard impact wrench with front exhaust
- Push button action for reverse

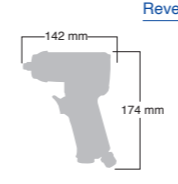

SI-1355
Maximum Torque :
90Nm

Maximum Torque Nm/(ft-lb)	90/(66)
Working Torque Range Nm/(ft-lb)	0-75/(0-55)
Bolt Cap mm/(in.)	10/(3/8)
Free Speed r.p.m.	9,000
Weight kg/(lb)	1.12/(2.47)
Noise Level dBA/(power)	80/(91)
Vibration a/k m/s ²	3.3/0.8
Max Air Consumption CFM/(L/S)	16.2/(7.6)
Avg Air Consumption CFM/(L/S)	2.7/(1.5)
Air Inlet Size in.	1/4
Hose Size mm/(in.)	10/(3/8)

SI-1365

3/8" Impact Wrench

- The ultimate design for a 3/8" sq drive impact wrench
- Precision machined air motor for durability Muffled exhaust for industrial use

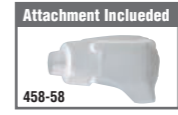
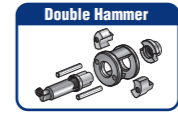

Attachment Included
458-58
Maximum Torque :
100Nm



Maximum Torque Nm/(ft-lb)	100/(74)
Working Torque Range Nm/(ft-lb)	0-80/(0-59)
Bolt Cap mm/(in.)	10/(3/8)
Free Speed r.p.m.	8,000
Weight kg/(lb)	1.31/(2.89)
Noise Level dBA/(power)	91/(102)
Vibration a/k m/s ²	8.3/1.3
Max Air Consumption CFM/(L/S)	19.8/(9.3)
Avg Air Consumption CFM/(L/S)	3.3/(1.6)
Air Inlet Size in.	1/4
Hose Size mm/(in.)	10/(3/8)

SI-1305

3/8" Impact Wrench

- 3/8"sq.palm grip Impact with butterfly throttle lever for quick and easy single hand operation
- 360° Air inlet swivel for easy manoeuvring

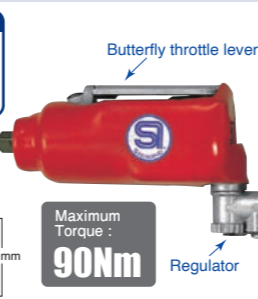
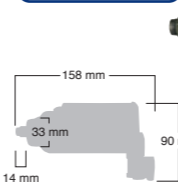
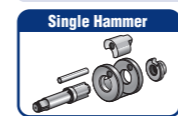

SI-1305
Maximum Torque :
90Nm

Maximum Torque Nm/(ft-lb)	90/(66)
Working Torque Range Nm/(ft-lb)	0-75/(0-55)
Bolt Cap mm/(in.)	10/(3/8)
Free Speed r.p.m.	9,000
Weight kg/(lb)	0.94/(2.08)
Noise Level dBA/(power)	91/(102)
Vibration a/k m/s ²	3.8/0.8
Max Air Consumption CFM/(L/S)	16.8/(7.9)
Avg Air Consumption CFM/(L/S)	2.8/(1.3)
Air Inlet Size in.	1/4
Hose Size mm/(in.)	10/(3/8)

SI-1650AH

1/2" Impact Wrench

- 90° head model
- Possible to turn the head 360°
- Ideal for changing the blade of tractors and farming equipment

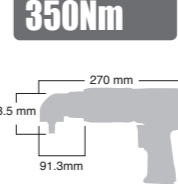

Attachment Included
103-1 736-8
Maximum Torque :
350Nm



Maximum Torque Nm/(ft-lb)	350/(258)
Working Torque Range Nm/(ft-lb)	0-280/(0-207)
Bolt Cap mm/(in.)	16/(5/8)
Free Speed r.p.m.	(F)7,500 (R)8,000
Weight kg/(lb)	2.80/(6.17)
Noise Level dBA/(power)	91/(102)
Vibration a/k m/s ²	18.1/2.2
Max Air Consumption CFM/(L/S)	24.0/(11.3)
Avg Air Consumption CFM/(L/S)	4.0/(1.9)
Air Inlet Size in.	1/4
Hose Size mm/(in.)	10/(3/8)

SI-1420T

1/2" Impact Wrench

- Higher powered impact wrench with 1/2"sq. anvil
- The twin hammer clutch delivers higher torque and faster power delivery

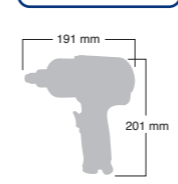

SI-1420T
Maximum Torque :
500Nm

Maximum Torque Nm/(ft-lb)	500/(369)
Working Torque Range Nm/(ft-lb)	0-400/(0-295)
Bolt Cap mm/(in.)	18/(11/16)
Free Speed r.p.m.	6,000
Weight kg/(lb)	2.55/(5.62)
Noise Level dBA/(power)	91/(102)
Vibration a/k m/s ²	7.3/1.2
Max Air Consumption CFM/(L/S)	24.0/(11.3)
Avg Air Consumption CFM/(L/S)	4.0/(1.9)
Air Inlet Size in.	1/4
Hose Size mm/(in.)	10/(3/8)

SI-1422T

1/2" Impact Wrench with 2" Extended Anvil

- The same quality features of SI-1420T with 2" extended anvil

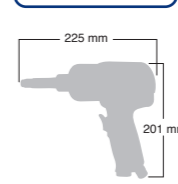

SI-1422T
Maximum Torque :
480Nm

Maximum Torque Nm/(ft-lb)	480/(354)
Working Torque Range Nm/(ft-lb)	0-360/(0-266)
Bolt Cap mm/(in.)	18/(11/16)
Free Speed r.p.m.	6,000
Weight kg/(lb)	2.65/(5.82)
Noise Level dBA/(power)	92/(103)
Vibration a/k m/s ²	8.2/1.3
Max Air Consumption CFM/(L/S)	24.0/(11.3)
Avg Air Consumption CFM/(L/S)	4.0/(1.9)
Air Inlet Size in.	1/4
Hose Size mm/(in.)	10/(3/8)

IMPACT WRENCHES
DRIVERS
RATCHET WRENCHES
SANDERS
POLISHERS
GRINDERS
DRILLS
SPOTLIGHTS
CUTTING TOOLS
OTHERS
INDUSTRIAL TOOLS
ACCESSORIES
SOUND & VIBRATION
MAINTENANCE CHECK
QUALITY

IMPACT WRENCHES

1/2" Impact Wrenches · 3/8" Impact Wrenches · 3/4" Impact Wrenches

SI-1357

3/8" Impact Wrench

- Ergonomic design, compact, and lightweight for easy operation.
- Easy to use in tight spaces.

Twin Hammer

Dimensions: 55mm, 126mm, 189mm

Maximum Torque : 200Nm

Easy to operate feather touch trigger
Reverse lever
Rubber grip for reduced vibration and temperature stability
Regulator Dial

Maximum Torque Nm/(ft-lb)	200/(147)
Working Torque Range Nm/(ft-lb)	0-160/(0-118)
Bolt Cap mm/(in.)	10/(3/8)
Free Speed r.p.m.	(F)8,000 (R)9,000
Weight kg/(lb)	1.10/(2.43)
Noise Level dBA/(power)	92/(103)
Vibration a/k m/s ²	7.6/1.2
Max Air Consumption CFM/(L/S)	21.6/(10.2)
Avg Air Consumption CFM/(L/S)	3.6/(1.7)
Air Inlet Size in.	1/4
Hose Size mm/(in.)	10/(3/8)

SI-1457

1/2" Impact Wrench

- Ergonomic design, compact, and lightweight for easy operation.
- Easy to use in tight spaces.

Twin Hammer

Dimensions: 55mm, 126mm, 189mm

Maximum Torque : 350Nm

Easy to operate feather touch trigger
Reverse lever
Rubber grip for reduced vibration and temperature stability
Regulator Dial

Maximum Torque Nm/(ft-lb)	350/(258)
Working Torque Range Nm/(ft-lb)	0-280/(0-207)
Bolt Cap mm/(in.)	16/(5/8)
Free Speed r.p.m.	(F)8,000 (R)9,000
Weight kg/(lb)	1.1/(2.43)
Noise Level dBA/(power)	92/(103)
Vibration a/k m/s ²	9.1/1.4
Max Air Consumption CFM/(L/S)	21.6/(10.2)
Avg Air Consumption CFM/(L/S)	3.6/(1.7)
Air Inlet Size in.	1/4
Hose Size mm/(in.)	10/(3/8)

IMPACT WRENCHES

1/2" Impact Wrenches · 3/4" Impact Wrenches

SI-1460

1/2" Impact Wrench

- Extremely high breakaway torque of 1400Nm.
- It combines light weight and high power.
- Strong jumbo single hammer clutch.
- Composite motor housing for reduced vibration and temperature stability.

Jumbo single Hammer

Dimensions: 74mm, 138mm, 189mm

Maximum Torque : 850Nm

Breakaway Torque **1,400Nm**

Only 1.57kg and 138mm length short size body.

Easy to operate feather touch trigger
Rubber grip for reduced vibration and temperature stability
Handle grip exhaust directs air away from operator and work space

SI-1460 **SI-1460SR**

4 Position speed selector & Forward/Reverse selector
SR: Max Power Reverse
Forward Adjustable 1~4
Reverse Maximum Power Only

	SI-1460	SI-1460SR
Maximum Torque Nm/(ft-lb)	850/(627)	850/(627)
Working Torque Range Nm/(ft-lb)	0-620/(0-457)	0-620/(0-457)
Bolt Cap mm/(in.)	20/(3/4)	20/(3/4)
Free Speed r.p.m.	(F)8,000 (R)8,500	(F)8,000 (R)8,500
Weight kg/(lb)	1.57/(3.46)	1.57/(3.46)
Noise Level dBA/(power)	88.3/(99.3)	88.3/(99.3)
Vibration a/k m/s ²	9.5/1.4	9.5/1.4
Max Air Consumption CFM/(L/S)	30.6/(14.4)	30.6/(14.4)
Avg Air Consumption CFM/(L/S)	5.1/(2.4)	5.1/(2.4)
Air Inlet Size in.	1/4	1/4
Hose Size mm/(in.)	10/(3/8)	10/(3/8)

SI-1490B

1/2" Impact Wrench

- Light weight, high power and well balanced.
- 4 positions regulator dial for easy adjustment and it has an forward, reverse lever for easy adjustment.
- Integrated muffler for reduced noise level

Twin Hammer

Dimensions: 74mm, 175mm, 189mm

Maximum Torque : 850Nm

Easy to operate feather touch trigger
Rubber grip for reduced vibration and temperature stability
Handle grip exhaust directs air away from operator and work space

SI-1490B **SI-1490BSR**

4 Position speed selector & Forward/Reverse selector
SR: Max Power Reverse
Forward Adjustable 1~4
Reverse Maximum Power Only

	SI-1490B	SI-1490BSR
Maximum Torque Nm/(ft-lb)	850/(627)	850/(627)
Working Torque Range Nm/(ft-lb)	0-620/(0-457)	0-620/(0-457)
Bolt Cap mm/(in.)	20/(3/4)	20/(3/4)
Free Speed r.p.m.	(F)8,000 (R)8,500	(F)8,000 (R)8,500
Weight kg/(lb)	1.9/(4.19)	1.9/(4.19)
Noise Level dBA/(power)	94/(105)	94/(105)
Vibration a/k m/s ²	8.6/1.3	8.6/1.3
Max Air Consumption CFM/(L/S)	30.6/(14.4)	30.6/(14.4)
Avg Air Consumption CFM/(L/S)	5.1/(2.4)	5.1/(2.4)
Air Inlet Size in.	1/4	1/4
Hose Size mm/(in.)	10/(3/8)	10/(3/8)

SI-1605/SI-1605SR

3/8" Impact Wrench

- Ergonomic design, compact, and lightweight for easy operation.
- Full power reverse helps to unfasten bolts quickly for changing wheels. (SI-1605SR)

Twin Hammer

Dimensions: 63mm, 148mm, 174mm

Maximum Torque : 350Nm

Easy to operate feather touch trigger
Rubber grip for reduced vibration and temperature stability
Integrated muffler for reduced noise level

SI-1605 **SI-1605SR**

Maximum Torque Nm/(ft-lb)	350/(258)
Working Torque Range Nm/(ft-lb)	0-280/(0-207)
Bolt Cap mm/(in.)	16/(5/8)
Free Speed r.p.m.	(F)8,000 (R)8,500
Weight kg/(lb)	1.03/(2.27)
Noise Level dBA/(power)	94/(105)
Vibration a/k m/s ²	7.7/1.3
Max Air Consumption CFM/(L/S)	22.8/(10.8)
Avg Air Consumption CFM/(L/S)	3.8/(1.8)
Air Inlet Size in.	1/4
Hose Size mm/(in.)	10/(3/8)

SI-1610/SI-1610SR

1/2" Impact Wrench

- Ergonomic design, compact, and lightweight for easy operation.
- One hand forward & reverse operation.
- Full power reverse helps to unfasten bolts quickly for changing wheels. (SI-1610SR)

Twin Hammer

Dimensions: 63mm, 148mm, 174mm

Maximum Torque : 450Nm

Easy to operate feather touch trigger
Rubber grip for reduced vibration and temperature stability
Integrated muffler for reduced noise level

SI-1610 **SI-1610SR**

Maximum Torque Nm/(ft-lb)	450/(332)
Working Torque Range Nm/(ft-lb)	0-320/(0-258)
Bolt Cap mm/(in.)	16/(5/8)
Free Speed r.p.m.	(F)8,000 (R)8,500
Weight kg/(lb)	1.04/(2.29)
Noise Level dBA/(power)	94/(105)
Vibration a/k m/s ²	7.7/1.3
Max Air Consumption CFM/(L/S)	22.8/(10.8)
Avg Air Consumption CFM/(L/S)	3.8/(1.8)
Air Inlet Size in.	1/4
Hose Size mm/(in.)	10/(3/8)

SI-1455SR

1/2" Impact Wrench

- Only 112 mm length short size body
- Strong jumbo hammer clutch
- Reverse button for one hand operation
- Composite motor housing for reduced vibration and temperature stability

Jumbo single Hammer

Dimensions: 63mm, 112mm, 190mm

Maximum Torque : 740Nm

Stubby & High Power

3 positions regulator dial for one hand easy adjustment

Maximum Torque Nm/(ft-lb)	740/(550)
Working Torque Range Nm/(ft-lb)	0-640/(0-470)
Bolt Cap mm/(in.)	16/(5/8)
Free Speed r.p.m.	(F)9,000 (R)9,000
Weight kg/(lb)	1.17/(2.57)
Noise Level dBA/(power)	98.7/(109.7)
Vibration a/k m/s ²	8.7/1.5
Max Air Consumption CFM/(L/S)	28.8/(13.6)
Avg Air Consumption CFM/(L/S)	4.8/(2.3)
Air Inlet Size in.	1/4
Hose Size mm/(in.)	10/(3/8)

SI-1492B/SI-1492BSR

1/2" Impact Wrench with 2" Extended Anvil

- The same quality features of SI-1490B & SI-1490BSR with 2" extended anvil

Twin Hammer

Dimensions: 74mm, 220mm, 189mm

Maximum Torque : 830Nm

Easy to operate feather touch trigger
Rubber grip for reduced vibration and temperature stability

SI-1492B **SI-1492BSR**

Maximum Torque Nm/(ft-lb)	830/(612)
Working Torque Range Nm/(ft-lb)	0-600/(0-443)
Bolt Cap mm/(in.)	20/(3/4)
Free Speed r.p.m.	(F)8,000 (R)8,500
Weight kg/(lb)	1.94/(4.28)
Noise Level dBA/(power)	94/(105)
Vibration a/k m/s ²	8.6/1.3
Max Air Consumption CFM/(L/S)	30.6/(14.4)
Avg Air Consumption CFM/(L/S)	5.1/(2.4)
Air Inlet Size in.	1/4
Hose Size mm/(in.)	10/(3/8)

SI-1550/SI-1550SR

3/4" Impact Wrench

- Rubber grip absorbs the vibration remarkably well and also protects your hand from the cold.
- 4 positions regulator dial for easy adjustment and it has an forward, reverse for easy adjustment.

Twin Hammer

Dimensions: 86mm, 218mm, 200mm

Maximum Torque : 1,650Nm

Easy to operate feather touch trigger
Rubber grip for reduced vibration and temperature stability
Handle grip exhaust directs air away from operator and work space

SI-1550 **SI-1550SR**

Maximum Torque Nm/(ft-lb)	1,650/(1,217)
Working Torque Range Nm/(ft-lb)	0-1,320/(0-974)
Bolt Cap mm/(in.)	24/(15/16)
Free Speed r.p.m.	(F)6,000 (R)6,500
Weight kg/(lb)	3.25/(7.7)
Noise Level dBA/(power)	92/(103)
Vibration a/k m/s ²	11.2/1.6
Max Air Consumption CFM/(L/S)	48.0/(22.6)
Avg Air Consumption CFM/(L/S)	8.0/(3.8)
Air Inlet Size in.	3/8
Hose Size mm/(in.)	13/(1/2)

SI-1556/SI-1556SR

3/4" Impact Wrench with 6" Extended Anvil

- SI-1550 & SI-1550SR with 6" extended anvil.
- 4 positions regulator dial for easy adjustment and it has an forward, reverse for easy adjustment.

Twin Hammer

Dimensions: 86mm, 366mm, 200mm

Maximum Torque : 1,550Nm

Easy to operate feather touch trigger
Rubber grip for reduced vibration and temperature stability
Handle grip exhaust directs air away from operator and work space

SI-1556 **SI-1556SR**

Maximum Torque Nm/(ft-lb)	1,550/(1,143)
Working Torque Range Nm/(ft-lb)	0-1,240/(0-915)
Bolt Cap mm/(in.)	24/(15/16)
Free Speed r.p.m.	(F)6,000 (R)6,500
Weight kg/(lb)	3.95/(8.71)
Noise Level dBA/(power)	93/(104)
Vibration a/k m/s ²	11.1/1.5
Max Air Consumption CFM/(L/S)	48.0/(22.6)
Avg Air Consumption CFM/(L/S)	8.0/(3.8)
Air Inlet Size in.	3/8
Hose Size mm/(in.)	13/(1/2)

IMPACT WRENCHES
DRIVERS
RATCHET WRENCHES
SCREWDRIVERS
POLISHERS
GRINDERS
SPOTLIGHTS
CUTTING TOOLS
OTHERS
INDUSTRIAL TOOLS
ACCESSORIES
SOUND & VIBRATION
MAINTENANCE CHECK
QUALITY

IMPACT WRENCHES 1" Impact Wrenches

SI-1555SR 1" Impact Wrench

- Pistol grip impact wrench with 1" sq. anvil.
- Rubber grip absorbs the vibration remarkably well and also protects your hand from the cold.
- 4 positions regulator dial for easy adjustment and it has an forward, reverse for easy adjustment.



Maximum Torque Nm/(ft-lb)	1,650/(1,217)
Working Torque Range Nm/(ft-lb)	0-1,320/(0-974)
Bolt Cap mm/(in.)	38/(1-1/2)
Free Speed r.p.m.	(F)6,000 (R)6,500
Weight kg/(lb)	3.5/(7.7)
Noise Level dBA/(power)	92/(103)
Vibration a/k m/s ²	11.2/1.6
Max Air Consumption CFM/(L/S)	48.0/(22.6)
Avg Air Consumption CFM/(L/S)	8.0/(3.8)
Air Inlet Size in.	3/8
Hose Size mm/(in.)	13/(1/2)

SI-1860 1" Impact Wrench

- Pistol grip impact wrench with 1" sq. anvil.
- 3-piece body construction engineered for easy maintenance.
- Pinless Hammer Clutch for High Durability.



Maximum Torque Nm/(ft-lb)	2,500/(1,840)
Working Torque Range Nm/(ft-lb)	1,000-2,200/(740-1,620)
Bolt Cap mm/(in.)	41/(1-10/16)
Free Speed r.p.m.	4,700
Weight kg/(lb)	10.9/(24.0)
Noise Level dBA/(power)	94/(105)
Vibration a/k m/s ²	8.8/1.3
Max Air Consumption CFM/(L/S)	82.7/(39.1)
Avg Air Consumption CFM/(L/S)	13.8/(6.5)
Air Inlet Size in.	1/2
Hose Size mm/(in.)	13/(1/2)

SI-1866 1" Impact Wrench with 6" Extended Anvil

- 6" extended anvil for easy reach into deep truck wheels.
- 3-piece body construction engineered for easy maintenance.
- Pinless Hammer Clutch for High Durability.



Maximum Torque Nm/(ft-lb)	2,400/(1,770)
Working Torque Range Nm/(ft-lb)	900-2,100/(670-1,550)
Bolt Cap mm/(in.)	41/(1-10/16)
Free Speed r.p.m.	4,700
Weight kg/(lb)	12.4/(27.3)
Noise Level dBA/(power)	95/(106)
Vibration a/k m/s ²	8.3/1.3
Max Air Consumption CFM/(L/S)	82.7/(39.1)
Avg Air Consumption CFM/(L/S)	13.8/(6.5)
Air Inlet Size in.	1/2
Hose Size mm/(in.)	13/(1/2)

SI-1870 1" Impact Wrench

- Straight body impact wrench with 1" sq. anvil and D handle.
- 3-piece body construction engineered for easy maintenance.
- Pinless Hammer Clutch for High Durability.
- Removable support handle can be rotated for left hand or right hand use.



Maximum Torque Nm/(ft-lb)	2,400/(1,770)
Working Torque Range Nm/(ft-lb)	880-2,100/(650-1,550)
Bolt Cap mm/(in.)	41/(1-10/16)
Free Speed r.p.m.	4,400
Weight kg/(lb)	10.6/(23.4)
Noise Level dBA/(power)	94/(105)
Vibration a/k m/s ²	9.3/1.4
Max Air Consumption CFM/(L/S)	69.0/(32.5)
Avg Air Consumption CFM/(L/S)	11.5/(5.4)
Air Inlet Size in.	1/2
Hose Size mm/(in.)	13/(1/2)

SI-1876 1" Impact Wrench with 6" Extended Anvil

- 6" extended anvil for easy reach into deep truck wheels.
- Pinless Hammer Clutch for High Durability.



Maximum Torque Nm/(ft-lb)	2,300/(1,700)
Working Torque Range Nm/(ft-lb)	830-2,000/(610-1,470)
Bolt Cap mm/(in.)	40/(1-9/16)
Free Speed r.p.m.	4,400
Weight kg/(lb)	12.1/(26.7)
Noise Level dBA/(power)	94/(105)
Vibration a/k m/s ²	12.1/1.7
Max Air Consumption CFM/(L/S)	69.0/(32.5)
Avg Air Consumption CFM/(L/S)	11.5/(5.4)
Air Inlet Size in.	1/2
Hose Size mm/(in.)	13/(1/2)

SI-1878 1" Impact Wrench with 8" Extended Anvil

- 8" extended anvil for easy reach into deep truck wheels.
- Pinless Hammer Clutch for High Durability.

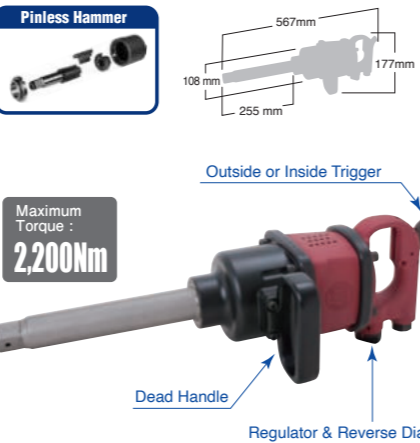

Maximum Torque Nm/(ft-lb)	2,200/(1,630)
Working Torque Range Nm/(ft-lb)	800-1,900/(590-1,400)
Bolt Cap mm/(in.)	40/(1-9/16)
Free Speed r.p.m.	4,400
Weight kg/(lb)	12.3/(27.1)
Noise Level dBA/(power)	94/(105)
Vibration a/k m/s ²	11.1/1.5
Max Air Consumption CFM/(L/S)	69.0/(32.5)
Avg Air Consumption CFM/(L/S)	11.5/(5.4)
Air Inlet Size in.	1/2
Hose Size mm/(in.)	13/(1/2)

IMPACT WRENCHES 1" Impact Wrenches · 1-1/2" Impact Wrench

SI-1880 1" Impact Wrench

SI-1880I: Inside Trigger model

- Heavy Duty high power 1" impact wrench
- 3-piece body construction engineered for easy maintenance.
- Pinless Hammer Clutch for High Durability.
- Removable support handle can be rotated for left hand or right hand use.



Maximum Torque Nm/(ft-lb)	3,300/(2,430)
Working Torque Range Nm/(ft-lb)	900-2,800/(660-2,060)
Bolt Cap mm/(in.)	50 (1-15/16)
Free Speed r.p.m.	3,000
Weight kg/(lb)	15.4/(33.8)
Noise Level dBA/(power)	92/(103)
Vibration a/k m/s ²	8.3/1.3
Max Air Consumption CFM/(L/S)	64.2/(30.3)
Avg Air Consumption CFM/(L/S)	10.7/(5.0)
Air Inlet Size in.	1/2
Hose Size mm/(in.)	13/(1/2)

SI-1888 1" Impact Wrench with 8" Extended Anvil

- 8" extended anvil for easy reach into deep truck wheels.
- 3-piece body construction engineered for easy maintenance.
- Pinless Hammer Clutch for High Durability.
- Removable support handle can be rotated for left hand or right hand use.



Maximum Torque Nm/(ft-lb)	3,200/(2,360)
Working Torque Range Nm/(ft-lb)	800-2,700/(590-1,990)
Bolt Cap mm/(in.)	50/(1-15/16)
Free Speed r.p.m.	3,000
Weight kg/(lb)	17.1/(37.7)
Noise Level dBA/(power)	92/(103)
Vibration a/k m/s ²	9.8/1.4
Max Air Consumption CFM/(L/S)	64.2/(30.3)
Avg Air Consumption CFM/(L/S)	10.7/(5.0)
Air Inlet Size in.	1/2
Hose Size mm/(in.)	13/(1/2)

SI-1900 1-1/2" Impact Wrench

SI-1900I: Inside Trigger model

- Heavy Duty impact wrench with 1-1/2" sq. anvil and D handle.
- 3-piece body construction engineered for easy maintenance.
- Removable support handle can be rotated for left hand or right hand use.



Maximum Torque Nm/(ft-lb)	5,500/(4,060)
Working Torque Range Nm/(ft-lb)	1,500-4,200/(1,110-3,100)
Bolt Cap mm/(in.)	55/(2-3/16)
Free Speed r.p.m.	3,600
Weight kg/(lb)	18.0/(39.7)
Noise Level dBA/(power)	107/(116)
Vibration m/s ²	9.3
Max Air Consumption CFM/(L/S)	79.7/(37.6)
Avg Air Consumption CFM/(L/S)	13.3/(6.3)
Air Inlet Size in.	1/2
Hose Size mm/(in.)	13/(1/2)

IMPACT CLUTCHES

Jumbo Single Hammer	Single Hammer	Double Hammer	Twin Hammer	Pin Clutch	Pinless Hammer
One hammer makes one impact per rotation.	Single hammer makes one impact per rotation.	Two hammers makes two impacts per rotation.	Two hammers make one impact per rotation.	One hammer makes one impact per rotation.	One hammer makes one impact per rotation.
This design is most compact and light weight hammer configuration. It's similar to the Twin Hammer but with a single hammer. The clutch creates extremely high torque and durability.	A single hammer is contained within the clutch rotor. This produces greater impact force per rotation and easy maintenance.	Twin hammers are contained within the clutch rotor. This design produces lower vibration levels and higher torque than a single hammer configuration.	This design is the most durable and light weight hammer configuration which produces less vibration, while maintaining high impact forces for its weight.	Cam driven engaging pins that extend and retract once per rotation, engaging the anvil with the hammer to produce high force impacts. This configuration produces the highest torque delivery in the range with minimum vibration.	The impact power is transmitted directly to the anvil by a unified hammer and hammer pin. This unified hammer configuration delivers high impact force with long service life and easy maintenance.



SI-1170

DRIVERS

IMPACT DRIVERS
SCREW DRIVERS



DRIVERS Impact Drivers

SI-1052

Impact Driver

- 6mm capacity straight grip impact driver
- Have regulator built-in
- Compact body design for reduce weight and easy operation

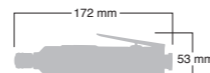
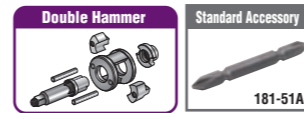

Shank Size in./ (mm)	1/4/(6.35)
Max Torque Nm/(ft-lb)	70/(51.6)
Working Torque Nm/(ft-lb)	0-60/(0-44)
Bolt Cap mm/ (in.)	5/(3/16)
Free Speed r.p.m.	13,000
Weight kg/ (lb)	0.56/(1.23)
Noise Level dBA/ (power)	90/(101)
Vibration a/k m/s ²	9.3/1.4
Max Air Consumption CFM/ (L/S)	13.8/(6.5)
Avg Air Consumption CFM/ (L/S)	2.3/(1.1)
Air Inlet Size in.	1/4

SI-1062

Impact Driver

- More powerful than SI-1052
- Built-in regulator
- Compact body design for reduce weight and easy operation

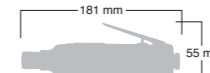
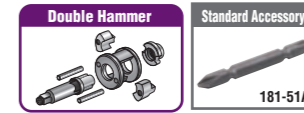

Shank Size in./ (mm)	1/4/(6.35)
Max Torque Nm/(ft-lb)	80/(70.1)
Working Torque Nm/(ft-lb)	0-70/(0-52)
Bolt Cap mm/ (in.)	6/(1/4)
Free Speed r.p.m.	10,000
Weight kg/ (lb)	0.79/(1.74)
Noise Level dBA/ (power)	87/(98)
Vibration a/k m/s ²	9.8/1.4
Max Air Consumption CFM/ (L/S)	16.8/(7.9)
Avg Air Consumption CFM/ (L/S)	2.8/(1.3)
Air Inlet Size in.	1/4

SI-1060

Impact Driver

- 6mm capacity straight grip impact driver
- Compact, lightweight, ergonomic design for easy operation
- General use

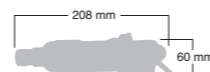
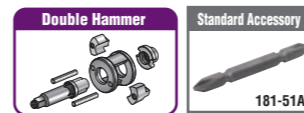

Shank Size in./ (mm)	1/4/(6.35)
Max Torque Nm/(ft-lb)	65/(47.9)
Working Torque Nm/(ft-lb)	0-50/(0-37)
Bolt Cap mm/ (in.)	6/(1/4)
Free Speed r.p.m.	11,000
Weight kg/ (lb)	0.87/(1.92)
Noise Level dBA/ (power)	89/(100)
Vibration a/k m/s ²	10.8/2.8
Max Air Consumption CFM/ (L/S)	17.4/(8.2)
Avg Air Consumption CFM/ (L/S)	2.9/(1.4)
Air Inlet Size in.	1/4

SI-1065

Impact Driver

- 6mm capacity pistol grip impact driver
- General use
- Ergonomic pistol grip for easy operation

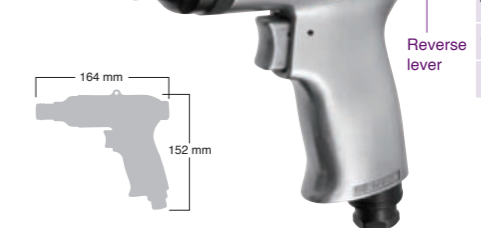
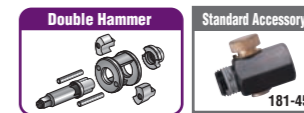

Shank Size in./ (mm)	1/4/(6.35)
Max Torque Nm/(ft-lb)	65/(47.9)
Working Torque Nm/(ft-lb)	0-45/(0-33)
Bolt Cap mm/ (in.)	6/(1/4)
Free Speed r.p.m.	11,000
Weight kg/ (lb)	0.98/(2.16)
Noise Level dBA/ (power)	88/(99)
Vibration a/k m/s ²	6.9/2.0
Max Air Consumption CFM/ (L/S)	20.4/(9.6)
Avg Air Consumption CFM/ (L/S)	3.4/(1.6)
Air Inlet Size in.	1/4

SI-1356D

Impact Driver

- 8mm capacity pistol grip impact driver
- Double hammer mechanism

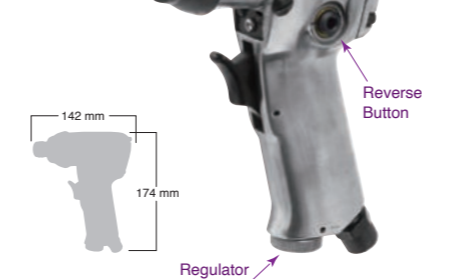

Shank Size in./ (mm)	1/4/(6.35)
Max Torque Nm/(ft-lb)	55/(40.6)
Working Torque Nm/(ft-lb)	0-45/(0-33)
Bolt Cap mm/ (in.)	8/(5/16)
Free Speed r.p.m.	9,000
Weight kg/ (lb)	1.22/(2.69)
Noise Level dBA/ (power)	87/(98)
Vibration a/k m/s ²	6.6/1.1
Max Air Consumption CFM/ (L/S)	16.2/(7.6)
Avg Air Consumption CFM/ (L/S)	2.7/(1.3)
Air Inlet Size in.	1/4

SI-1365D

Impact Driver

- 8mm capacity pistol grip impact driver
- Industrial use

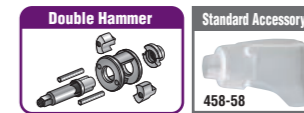

Shank Size in./ (mm)	1/4/(6.35)
Max Torque Nm/(ft-lb)	70/(51.6)
Working Torque Nm/(ft-lb)	0-60/(0-44)
Bolt Cap mm/ (in.)	8/(5/16)
Free Speed r.p.m.	8,000
Weight kg/ (lb)	1.32/(2.92)
Noise Level dBA/ (power)	84/(95)
Vibration a/k m/s ²	7.6/2.6
Max Air Consumption CFM/ (L/S)	19.8/(9.3)
Avg Air Consumption CFM/ (L/S)	3.3/(1.6)
Air Inlet Size in.	1/4

IMPACT WRENCHES

DRIVERS

RATCHET WRENCHES

SANDERS

POLISHERS

GRINDERS

DRILLS SPOTLIGHTS

CUTTING TOOLS

OTHERS

INDUSTRIAL TOOLS

ACCESSORIES

SOUND & VIBRATION

MAINTENANCE CHECK

QUALITY

SI-1070

Impact Driver

- 6mm capacity pistol grip impact driver
- General use
- Compact, lightweight and a "feather touch" trigger for easy operation.

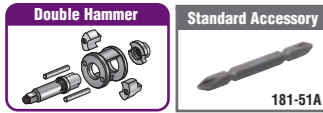

Shank Size in./ (mm)	1/4/(6.35)
Max Torque Nm/(ft-lb)	35/(25.8)
Working Torque Nm/(ft-lb)	0-30/(0-22)
Bolt Cap mm/(in.)	6/(1/4)
Free Speed r.p.m.	11,000
Weight kg/(lb)	0.65/(1.43)
Noise Level dBA/(power)	83/(94)
Vibration a/k m/s ²	6.4/2.1
Max Air Consumption CFM/(L/S)	12.6/(5.9)
Avg Air Consumption CFM/(L/S)	2.1/(1.0)
Air Inlet Size in.	1/4

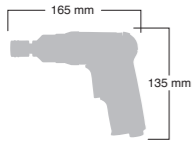

SI-1170

Screw Driver

- An adjustment ring with easy torque adjustment
- The full composite tool of an original design
- An oscillation is eased by a soft grip



Shank Size in./ (mm)	1/4/(6.35)
Max Torque Nm/(ft-lb)	20/(14.8)
Working Torque Nm/(ft-lb)	4-11/(2.9-8.1)
Bolt Cap mm/(in.)	8/(5/16)
Free Speed r.p.m.	700
Weight kg/(lb)	0.85/(1.87)
Noise Level dBA/(power)	85/(96)
Vibration a/k m/s ²	0.8/0.5
Max Air Consumption CFM/(L/S)	13.8/(6.5)
Avg Air Consumption CFM/(L/S)	2.3/(1.1)
Air Inlet Size in.	1/4

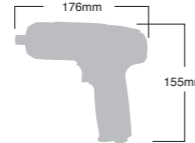

SI-1140

Screw Driver

- 4mm capacity straight grip screw driver
- Clutch mechanism for easy adjustment of maximum torque

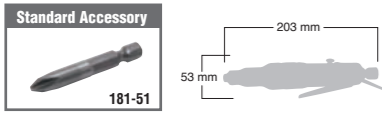

Shank Size in./ (mm)	1/4/(6.35)
Max Torque Nm/(ft-lb)	1.5/(1.1)
Working Torque Nm/(ft-lb)	0.3-1.5/(0.2-1.1)
Bolt Cap mm/(in.)	4/(5/32)
Free Speed r.p.m.	1,700
Weight kg/(lb)	0.62/(1.36)
Noise Level dBA/(power)	80/(91)
Vibration a/k m/s ²	0.2/0.5
Max Air Consumption CFM/(L/S)	11.4/(5.4)
Avg Air Consumption CFM/(L/S)	1.9/(0.9)
Air Inlet Size in.	1/4

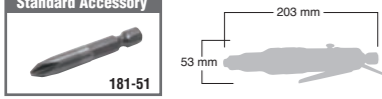

SI-1161

Screw Driver

- 6mm capacity straight grip screw driver
- Adjustable clutch
- Compact, lightweight, and ergonomic design for easy operation



Shank Size in./ (mm)	1/4/(6.35)
Max Torque Nm/(ft-lb)	5.0/(3.7)
Working Torque Nm/(ft-lb)	1.5-5.0/(1.1-3.7)
Bolt Cap mm/(in.)	6/(1/4)
Free Speed r.p.m.	1,600
Weight kg/(lb)	1.12/(2.46)
Noise Level dBA/(power)	85/(96)
Vibration a/k m/s ²	0.3/0.5
Max Air Consumption CFM/(L/S)	16.8/(7.9)
Avg Air Consumption CFM/(L/S)	2.8/(1.3)
Air Inlet Size in.	1/4



SI-1166A

Screw Driver

- 6mm capacity pistol grip screw driver Adjustable clutch
- Ergonomic pistol grip for easy operation

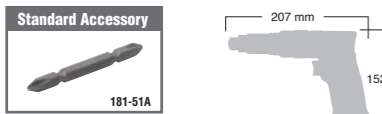

Shank Size in./ (mm)	1/4/(6.35)
Max Torque Nm/(ft-lb)	5.0/(3.7)
Working Torque Nm/(ft-lb)	1.5-5.0/(1.1-3.7)
Bolt Cap mm/(in.)	6/(1/4)
Free Speed r.p.m.	2,000
Weight kg/(lb)	1.18/(2.60)
Noise Level dBA/(power)	88/(99)
Vibration a/k m/s ²	0.4/0.5
Max Air Consumption CFM/(L/S)	21.0/(9.9)
Avg Air Consumption CFM/(L/S)	3.5/(1.6)
Air Inlet Size in.	1/4

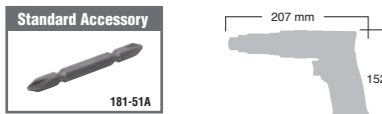

SI-1166-8A

Screw Driver

- 8mm capacity pistol grip screw driver Adjustable clutch
- Ergonomic pistol grip for easy operation



Shank Size in./ (mm)	1/4/(6.35)
Max Torque Nm/(ft-lb)	9.0/(6.6)
Working Torque Nm/(ft-lb)	1.5-9.0/(1.1-6.6)
Bolt Cap mm/(in.)	8/(5/16)
Free Speed r.p.m.	800
Weight kg/(lb)	1.35/(2.97)
Noise Level dBA/(power)	91/(102)
Vibration a/k m/s ²	1.0/0.6
Max Air Consumption CFM/(L/S)	19.8/(9.3)
Avg Air Consumption CFM/(L/S)	3.3/(1.6)
Air Inlet Size in.	1/4



SI-1218EX

RATCHET WRENCHES

- 1/4" RATCHET WRENCHES
- 3/8" RATCHET WRENCHES
- 1/2" RATCHET WRENCHES
- HEX 17mm THROUGH RATCHET WRENCH

RATCHET WRENCHES

1/2" Ratchet Wrenches • 3/8" Ratchet Wrenches • HEX 17mm Through

SI-1241A

3/8" Ratchet Wrench

- Swivel head with 9 levels
- An activity is possible at the locations which cannot work in the usual spanner and/or ratchet wrenches.
- The socket lock mechanism does not drop a socket on a narrow place.
- Japan and Foreign patent(s) pending as the "Quick release function" for easily releasing sockets

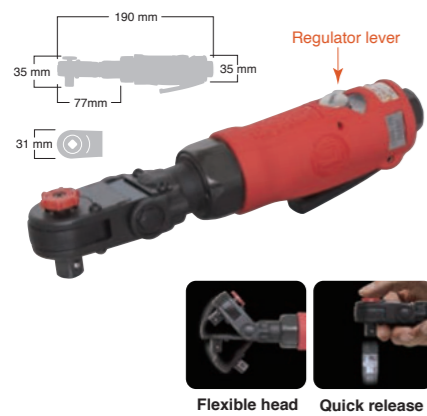

Shank Size in./ (mm)	3/8 / (9.5)
Maximum Torque Nm/ (ft-lb)	30/(22.1)
Working Torque Range Nm/ (ft-lb)	0-25/(0-18.4)
Bolt Cap mm/ (in.)	10/(3/8)
Free Speed r.p.m.	250
Weight kg/ (lb)	0.63/(1.38)
Noise Level dBA/ (power)	83/(94)
Vibration a/k m/s ²	11.3/1.6
Max Air Consumption CFM/ (L/S)	11.4/(5.4)
Avg Air Consumption CFM/ (L/S)	1.9/(0.9)
Air Inlet Size in.	1/4



The flexible head can reach at tight spaces.

SI-1261

3/8" Ratchet Wrench

- Japan and foreign patent(s) pending as the "Slide Switch" for the reverse function
- Plastic covered regular size body
- The lightest 960g in this class
- Lightweight and high strength super duralumin is used for housing

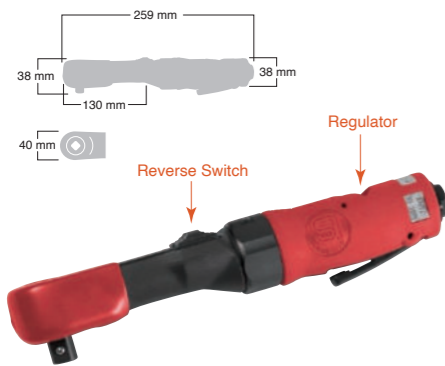

Shank Size in./ (mm)	3/8 / (9.5)
Maximum Torque Nm/ (ft-lb)	110/(81)
Working Torque Range Nm/ (ft-lb)	0-65/(0-48)
Bolt Cap mm/ (in.)	10/(3/8)
Free Speed r.p.m.	170
Weight kg/ (lb)	1.20/(2.65)
Noise Level dBA/ (power)	84/(95)
Vibration a/k m/s ²	5.1/1.0
Max Air Consumption CFM/ (L/S)	18.0/(8.5)
Avg Air Consumption CFM/ (L/S)	3.0/(1.4)
Air Inlet Size in.	1/4

SI-1262

1/2" Ratchet Wrench

- Japan and foreign patent(s) pending as the "Slide Switch" for the reverse function
- Plastic covered regular size body
- The lightest 970g in this class we have ever had
- Lightweight and high strength super duralumin is used for housing

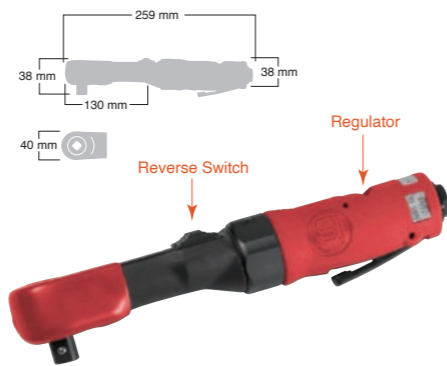

Shank Size in./ (mm)	1/2 / (12.7)
Maximum Torque Nm/ (ft-lb)	115/(85)
Working Torque Range Nm/ (ft-lb)	0-70/(0-52)
Bolt Cap mm/ (in.)	14/(9/16)
Free Speed r.p.m.	170
Weight kg/ (lb)	1.21/(2.67)
Noise Level dBA/ (power)	84/(95)
Vibration a/k m/s ²	5.0/1.0
Max Air Consumption CFM/ (L/S)	18.0/(8.5)
Avg Air Consumption CFM/ (L/S)	3.0/(1.4)
Air Inlet Size in.	1/4

SI-1435

1/2" Ratchet Wrench

- The largest ratchet wrench in the range with the highest torque
- 1/2" sq. anvil
- Good for running nuts on tractor blades

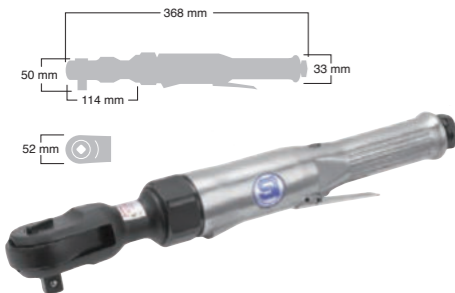

Shank Size in./ (mm)	1/2 / (12.7)
Maximum Torque Nm/ (ft-lb)	160/(118)
Working Torque Range Nm/ (ft-lb)	0-110/(0-81)
Bolt Cap mm/ (in.)	16/(5/8)
Free Speed r.p.m.	140
Weight kg/ (lb)	1.95/(4.31)
Noise Level dBA/ (power)	93/(104)
Vibration a/k m/s ²	5.4/1.0
Max Air Consumption CFM/ (L/S)	28.2/(13.3)
Avg Air Consumption CFM/ (L/S)	4.7/(2.2)
Air Inlet Size in.	1/4

SI-1288

HEX 17mm Through

- Ratchet wrench with the unique interchangeable inner sockets
- Specially designed for using in small space
- Include 8mm, 10mm, 11mm, 12mm, 13mm and 14mm sockets

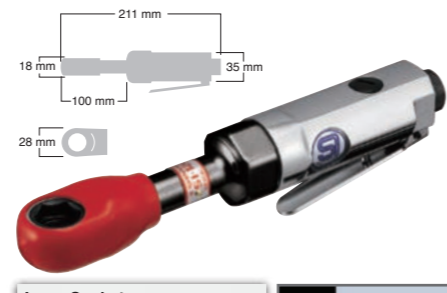

Shank Size in./ (mm)	HEX 17mm
Maximum Torque Nm/ (ft-lb)	45/(33)
Working Torque Range Nm/ (ft-lb)	0-35/(0-26)
Bolt Cap mm/ (in.)	8-17/(5/16-11/16)
Free Speed r.p.m.	180
Weight kg/ (lb)	0.54/(1.20)
Noise Level dBA/ (power)	84/(95)
Vibration a/k m/s ²	6.8/1.1
Max Air Consumption CFM/ (L/S)	11.4/(5.4)
Avg Air Consumption CFM/ (L/S)	1.9/(0.9)
Air Inlet Size in.	1/4



SI-3121-6

SANDERS

- BELT SANDERS
- CENTRAL VACUUM DUAL ACTION SANDERS
- DUAL ACTION SANDERS
- SELF VACUUM DUAL ACTION SANDERS
- MINI DUAL ACTION SANDERS
- SELF VACUUM GEARED DUAL ACTION SANDERS
- MINI SELF VACUUM DUAL ACTION SANDERS
- ORBITAL SANDERS
- SELF VACUUM ORBITAL SANDERS
- DISC SANDERS
- MINI SANDER
- HEAVY DUTY MINI SANDERS
- OSCILLATION SANDER
- WET SANDER
- MINI ORBITAL FINISHING SANDER

SI-2740

10mm Belt Sander

- 10mm sanding belt sander
- Super light & ergonomic design
- Rubber grip giving comfortable operation and reducing vibration

OPTION

509-45Z/40	10mm Sanding belt #40
509-45Z/80	10mm Sanding belt #80
509-45Z/100	10mm Sanding belt #100
509-45Z/120	10mm Sanding belt #120

SI-2741

12mm Belt Sander

Adjustable 160° Sanding arm

Light weight composite construction

Includes air regulator for quick speed adjustment

Quick change belt replacement lever

	SI-2740	SI-2741
Belt Size mm	10 x 330	12 x 330
Free Speed r.p.m.	15,000	15,000
Out Put Watt	317	317
Weight kg/(lb)	0.73/(1.61)	0.73/(1.61)
Noise Level dBA/(power)	85/(96)	85/(96)
Vibration a/k m/s ²	1.0/0.6	1.0/0.6
Max Air Consumption CFM/(L/S)	19.8/(9.3)	19.8/(9.3)
Avg Air Consumption CFM/(L/S)	3.3/(1.6)	3.3/(1.6)

SI-2740

Standard Accessory 509-45Z/60 10mm Sanding belt #60x6

Standard Accessory 181-45

SI-2741

Standard Accessory 509-60Z/12 12mm Sanding belt #60x6

SI-2700

10mm Belt Sander

- 10mm sanding belt sander
- Quick and easy belt change
- Adjustable arm angle

OPTION

509-45Z/40	10mm Sanding belt #40
509-45Z/80	10mm Sanding belt #80
509-45Z/100	10mm Sanding belt #100
509-45Z/120	10mm Sanding belt #120

Adjustable 160° Sanding arm

Quick change belt replacement lever

	SI-2700
Belt Size mm	10x330
Free Speed r.p.m.	15,000
Out Put Watt	317
Weight kg/(lb)	0.82/(1.82)
Noise Level dBA/(power)	86/(99)
Vibration a/k m/s ²	2.2/0.7
Max Air Consumption CFM/(L/S)	19.8/(9.3)
Avg Air Consumption CFM/(L/S)	3.3/(1.6)

Standard Accessory 509-45Z/60 10mm Sanding belt #60x6

SI-2700L

10mm Belt Sander

Head rotates 120 degrees for operating convenience. Variable speed throttle for positive control.

- Best for the light grinding, sanding and deburring. (SI-2700L)
- For nugget grinding of spot welding (SI-2700LS)

SI-2700LS

13mm Belt Sander

	SI-2700L	SI-2700LS
Belt Size mm	10x460	13x460
Free Speed r.p.m.	15,000	15,000
Out Put Watt	317	317
Weight kg/(lb)	0.85/(1.87)	0.9/(1.98)
Noise Level dBA/(power)	83/(94)	84/(95)
Vibration a/k m/s ²	2.5/0.7	1.6/0.6
Max Air Consumption CFM/(L/S)	19.8/(9.3)	19.8/(9.3)
Avg Air Consumption CFM/(L/S)	3.3/(1.6)	3.3/(1.6)

Standard Accessory 509-130 10mm Felt belt #60 x 1

Standard Accessory 509-131 10mm Felt belt #150 x 1

Standard Accessory 509-132 10mm Felt belt #320 x 1

Standard Accessory 509LK-106 13mm Sanding belt #60 x 5

SI-2800

20mm Belt Sander

- 20mm sanding belt sander
- Safety cover over belt wheel

OPTION

507-58Z/40	20mm Sanding belt #40
507-58Z/80	20mm Sanding belt #80
507-58Z/100	20mm Sanding belt #100
507-58Z/120	20mm Sanding belt #120

SI-2830

30mm Belt Sander

- 30mm sanding belt sander
- Safety cover over belt wheel
- Side handle for firm tool control

OPTION

505-56Z/40	30mm Sanding belt #40
505-56Z/80	30mm Sanding belt #80
505-56Z/100	30mm Sanding belt #100
505-56Z/120	30mm Sanding belt #120

	SI-2800	SI-2830
Belt Size mm	20x520	30x540
Free Speed r.p.m.	15,000	10,000
Out Put Watt	429	582
Weight kg/(lb)	1.43/(3.14)	2.02/(4.45)
Noise Level dBA/(power)	84/(95)	86/(97)
Vibration a/k m/s ²	3.0/0.8	1.6/0.6
Max Air Consumption CFM/(L/S)	22.8/(10.8)	31.8/(15.0)
Avg Air Consumption CFM/(L/S)	3.8/(1.8)	5.3/(2.5)

Standard Accessory 507-58Z/60 20mm Sanding belt #60x6

Standard Accessory 505-56Z/60 30mm Sanding belt #60x6

SI-3121-6

Central Vacuum Dual Action Sander with 6" pad

- Central vacuum dual action sander for dust extraction system and vacuum cleaner
- Light weight and compact palm grip body
- 6" multihole pad giving speedy operation

Standard Accessory

M-150HDMH	ø6" Velcro
SI-3121-6	ø6" Face Cover
SI-3121-6	ø6" Net paper #240x1 #120x1
SI-3121-6	NP-150-240 NP-150-120

SI-3121

SI-3121M : Velcro pad model

Central Vacuum Dual Action Sander with 5" pad

6" Multihole pad

Vacuum power adjuster

	SI-3121-6	SI-3121/3121M
Pad/Disc Size mm/(in.)	150(6")	125(5")
Spindle Size	5/16-24UNF	5/16-24UNF
Orbit Dia mm	5	5
Free Speed r.p.m.	10,000	10,000
Out Put Watt	148	148
Weight kg/(lb)	1.31/(2.88)	1.29/(2.83)
Noise Level dBA/(power)	81/(92)	81/(92)
Vibration a/k m/s ²	13.4/1.8	12.8/1.7
Max Air Consumption CFM/(L/S)	13.8/(6.5)	13.8/(6.5)
Avg Air Consumption CFM/(L/S)	2.3/(1.1)	2.3/(1.1)

Standard Accessory

SI-3121M	ø5" Velcro
SI-3121M	ø5" Leather
SI-3121M	570-42A

SI-3101LG

Dual Action Sander with 5" leather pad

- Low center of gravity dual action sander.
- The stable power can fully be delivered.
- Super light weight and easy to grip composite body cover.

SI-3101LGM

Dual Action Sander with 5" velcro pad

Low center of gravity design

	SI-3101LG	SI-3101LGM
Pad/Disc Size mm/(in.)		125(5")
Spindle Size		5/16-24UNF
Orbit Dia mm		5
Free Speed r.p.m.		10,000
Out Put Watt		148
Weight kg/(lb)		0.88/(1.94)
Noise Level dBA/(power)		88/(99)
Vibration a/k m/s ²		13.7/1.8
Max Air Consumption CFM/(L/S)		13.2/(6.2)
Avg Air Consumption CFM/(L/S)		2.2/(1.0)

Standard Accessory

SI-3101LG	ø5" Leather
SI-3101LGM	ø5" Velcro
SI-3101LG	P-125H
SI-3101LGM	M-125H

SI-3111LG

Self vacuum Dual Action Sander with 5" leather pad

- Low center of gravity self vacuum dual action sander.
- The stable power can fully be delivered.
- Super light weight and easy to grip composite body cover.

SI-3111LGM

Self vacuum Dual Action Sander with 5" velcro pad

Low center of gravity design

	SI-3111LG	SI-3111LGM
Pad/Disc Size mm/(in.)		125(5")
Spindle Size		5/16-24UNF
Orbit Dia mm		5
Free Speed r.p.m.		10,000
Out Put Watt		148
Weight kg/(lb)		1.23/(2.71)
Noise Level dBA/(power)		88/(99)
Vibration a/k m/s ²		13.7/1.8
Max Air Consumption CFM/(L/S)		13.8/(6.5)
Avg Air Consumption CFM/(L/S)		2.3/(1.1)

Standard Accessory

SI-3111LG	ø5" Leather
SI-3111LGM	ø5" Velcro
SI-3111LG	P-125HD
SI-3111LGM	M-125HD
SI-3111LGM	1040-54
SI-3111LGM	485-42

SI-3103B

SI-3103BM : Velcro pad model

Dual Action Sander with 5" pad

- Heavy duty action sander for factory work.
- Powerful high quality air motor.
- Durable mechanism ensures a long working life.

Heavy Duty Type

	SI-3103B	SI-3103BM
Pad/Disc Size mm/(in.)		125(5")
Spindle Size		5/16-24UNF
Orbit Dia mm		5
Free Speed r.p.m.		9,000
Out Put Watt		134
Weight kg/(lb)		1.18/(2.60)
Noise Level dBA/(power)		87/(98)
Vibration a/k m/s ²		15.6/2.0
Max Air Consumption CFM/(L/S)		16.8/(7.9)
Avg Air Consumption CFM/(L/S)		2.8/(1.3)

Standard Accessory

SI-3103B	ø5" Leather
SI-3103BM	ø5" Velcro
SI-3103B	P-125H
SI-3103BM	M-125H

SI-3103A

SI-3103AM : Velcro pad model

Dual Action Sander with 5" pad

- Standard dual action sander with palm grip 5" pad are available (SI-3103A)
- Powerful, high quality air motor
- 5mm orbit diameter Suitable for both rough and finish sanding
- The same quality features of SI-3103 with 6" pad model (SI-3103-6A)

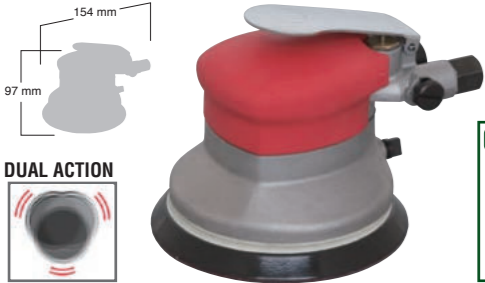

SI-3103-6A

SI-3103-6AM : Velcro pad model

Dual Action Sander with 6" pad



	SI-3103A/3103AM	SI-3103-6A/3103-6AM
Pad/Disc Size mm/(in.)	125/(5")	150/(6")
Spindle Size	5/16-24UNF	5/16-24UNF
Orbit Dia mm	5	5
Free Speed r.p.m.	9,000	9,000
Out Put Watt	134	134
Weight kg/(lb)	1.18/(2.60)	1.20/(2.64)
Noise Level dBA/(power)	80/(91)	80/(91)
Vibration a/k m/s ²	10.6/1.5	11.5/1.6
Max Air Consumption CFM/(L/S)	16.8/(7.9)	16.8/(7.9)
Avg Air Consumption CFM/(L/S)	2.8/(1.3)	2.8/(1.3)

SI-3118A

SI-3118AM : Velcro pad model

Self Vacuum Dual Action Sander with 5" pad

- Self vacuum dual action sander with 5" pad model (SI-3118A)
- The self generating suction system makes for a clean working environment
- Bar grip body
- Dust free operation protects the operator from the harmful particles of paint and filler
- The same quality features of SI-3118A with 6" pad model (SI-3118-6A)



SI-3118-6A

SI-3118-6AM : Velcro pad model

Self Vacuum Dual Action Sander with 6" pad



	SI-3118A/3118AM	SI-3118-6A/3118-6AM
Pad/Disc Size mm/(in.)	125/(5")	150/(6")
Spindle Size	5/16-24UNF	5/16-24UNF
Orbit Dia mm	6	6
Free Speed r.p.m.	8,000	8,000
Out Put Watt	569	569
Weight kg/(lb)	2.11/(4.65)	2.15/(4.74)
Noise Level dBA/(power)	81/(92)	81/(92)
Vibration a/k m/s ²	9.0/1.4	10.1/1.5
Max Air Consumption CFM/(L/S)	17.4/(8.2)	17.4/(8.2)
Avg Air Consumption CFM/(L/S)	2.9/(1.4)	2.9/(1.4)

SI-3113A

SI-3113AM : Velcro pad model

Self Vacuum Dual Action Sander with 5" pad

- Self vacuum dual action sander with 5" pad model (SI-3113A)
- The self generating dust system helps create a clean working environment, protecting the operator from harmful paint and filler particles
- Light weight and compact palm grip body
- The same quality features of SI-3113 with 9 holes 6" leather pad model (SI-3113-6A)

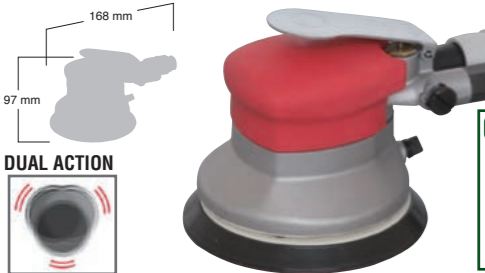

SI-3113-6A

SI-3113-6AM : Velcro pad model

Self Vacuum Dual Action Sander with 6" pad



	SI-3113A/3113AM	SI-3113-6A/3113-6AM
Pad/Disc Size mm/(in.)	125/(5")	150/(6")
Spindle Size	5/16-24UNF	5/16-24UNF
Orbit Dia mm	5	5
Free Speed r.p.m.	9,000	9,000
Out Put Watt	134	134
Weight kg/(lb)	1.57/(3.46)	1.59/(3.50)
Noise Level dBA/(power)	83/(94)	83/(94)
Vibration a/k m/s ²	13.6/1.8	13.2/2.9
Max Air Consumption CFM/(L/S)	14.4/(6.8)	14.4/(6.8)
Avg Air Consumption CFM/(L/S)	2.4/(1.1)	2.4/(1.1)

SI-3115R

Self Vacuum Geared Dual Action Sander with 5" pad

- Geared sander with 5" Velcro pad (SI-3115R)
- Amazing power is generated with the gear mechanism
- The same quality features of SI-3115R with 6" velcro pad model (SI-3115R-6)



SI-3115R-6

Self Vacuum Geared Dual Action Sander with 6" pad



	SI-3115R	SI-3115R-6
Pad/Disc Size mm/(in.)	125/(5")	150/(6")
Orbit Dia mm	4.4	4.4
Free Speed r.p.m.	1,000	1,000
Out Put Watt	148	148
Weight kg/(lb)	1.49/(3.27)	1.51/(3.33)
Noise Level dBA/(power)	86/(97)	86/(97)
Vibration a/k m/s ²	11.2/1.6	9.7/2.9
Max Air Consumption CFM/(L/S)	13.8/(6.5)	13.8/(6.5)
Avg Air Consumption CFM/(L/S)	2.3/(1.1)	2.3/(1.1)

SI-3101

SI-3101M : Velcro pad model

Dual Action Sander with 5" pad

- Light weight and compact palm grip body makes smooth and easy operation
- 5" pad also available 5mm orbit diameter for finish sanding (SI-3101)
- Ergonomic, compact and lightweight design for easy operation
- The same quality features of SI-3101 with 6" pad model (SI-3101-6)



SI-3101-6

SI-3101-6M : Velcro pad model

Dual Action Sander with 6" pad



	SI-3101/3101M	SI-3101-6/3101-6M
Pad/Disc Size mm/(in.)	125/(5")	150/(6")
Spindle Size	5/16-24UNF	5/16-24UNF
Orbit Dia mm	5	5
Free Speed r.p.m.	10,000	10,000
Out Put Watt	148	148
Weight kg/(lb)	0.92/(2.03)	0.94/(2.07)
Noise Level dBA/(power)	84/(95)	84/(95)
Vibration a/k m/s ²	14.4/1.9	10.4/2.3
Max Air Consumption CFM/(L/S)	13.2/(6.2)	13.2/(6.2)
Avg Air Consumption CFM/(L/S)	2.2/(1.0)	2.2/(1.0)

SI-3100

SI-3100M : Velcro pad model

Dual Action Sander with 6" pad

- Multi purpose dual action sander with bargrip
- 7mm orbit diameter for aggressive but smooth sanding
- The best and longest selling 6" random orbit model

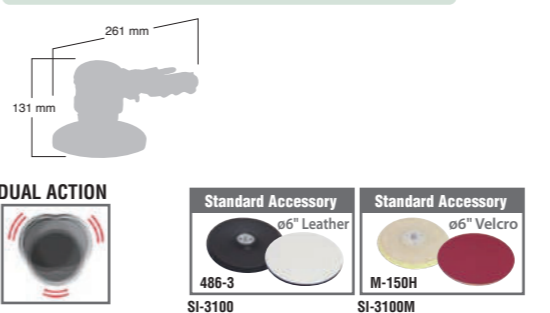

	SI-3100M
Pad/Disc Size mm/(in.)	150/(6")
Spindle Size	5/16-24UNF
Orbit Dia mm	7
Free Speed r.p.m.	10,000
Out Put Watt	542
Weight kg/(lb)	1.82/(4.01)
Noise Level dBA/(power)	75/(86)
Vibration a/k m/s ²	10.2/1.5
Max Air Consumption CFM/(L/S)	13.8/(6.5)
Avg Air Consumption CFM/(L/S)	2.3/(1.1)

SI-3111

SI-3111M : Velcro pad model

Self Vacuum Dual Action Sander with 5" pad

- Self vacuum dual action sander
- The self generating dust system helps create a clean working environment, protecting the operator from harmful paint and filler particles
- Light weight and compact palm grip body
- The same quality features of SI-3111 with 6" pad model (SI-3111-6)

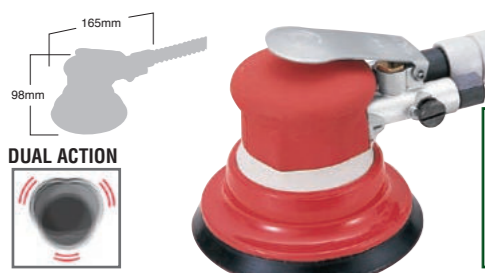

SI-3111-6

SI-3111-6M : Velcro pad model

Self Vacuum Dual Action Sander with 6" pad



	SI-3111/3111M	SI-3111-6/3111-6M
Pad/Disc Size mm/(in.)	125/(5")	150/(6")
Spindle Size	5/16-24UNF	5/16-24UNF
Orbit Dia mm	5	5
Free Speed r.p.m.	10,000	10,000
Out Put Watt	148	148
Weight kg/(lb)	1.27/(2.81)	1.29/(2.84)
Noise Level dBA/(power)	88/(99)	88/(99)
Vibration a/k m/s ²	10.2/1.5	11.7/1.6
Max Air Consumption CFM/(L/S)	13.8/(6.5)	13.8/(6.5)
Avg Air Consumption CFM/(L/S)	2.3/(1.1)	2.3/(1.1)

SI-3102M

Mini Dual Action Sander with 3" pad

- Compact body design easy one hand operation



Pad/Disc Size mm/(in.)	75/(3")
Spindle Size	5/16-24UNF
Orbit Dia mm	3
Free Speed r.p.m.	12,000
Out Put Watt	153
Weight kg/(lb)	0.54/(1.19)
Noise Level dBA/(power)	85/(96)
Vibration a/k m/s ²	7.4/1.2
Max Air Consumption CFM/(L/S)	15.0/(7.1)
Avg Air Consumption CFM/(L/S)	2.5/(1.2)

SI-3112M

Mini Self Vacuum Dual Action Sander with 3" pad

- Compact body design easy one hand operation



Pad/Disc Size mm/(in.)	75/(3")
Spindle Size	5/16-24UNF
Orbit Dia mm	3
Free Speed r.p.m.	12,000
Out Put Watt	153
Weight kg/(lb)	0.89/(1.96)
Noise Level dBA/(power)	92/(103)
Vibration a/k m/s ²	6.6/1.1
Max Air Consumption CFM/(L/S)	15.0/(7.1)
Avg Air Consumption CFM/(L/S)	2.5/(1.2)

SI-3001A

Orbital Sander

- Light weight and compact palm grip orbital sander
- Paper size : 75mm x 110mm

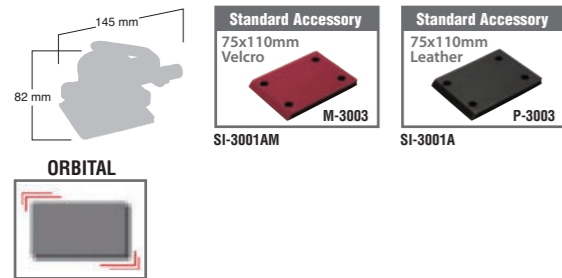

SI-3001AM

Orbital Sander with velcro pad



Pad/Disc Size mm/(in.)	75x100
Orbit Dia mm	4
Free Speed r.p.m.	10,000
Out Put Watt	148
Weight kg/(lb)	0.80/(1.77)
Noise Level dBA/(power)	82/(93)
Vibration a/k m/s ²	6.2/1.1
Max Air Consumption CFM/(L/S)	13.8/(6.5)
Avg Air Consumption CFM/(L/S)	2.3/(1.1)

SI-3011A

Self Vacuum Orbital Sander

- Self vacuum orbital sander with palm grip and leather pad
- Light weight and compact body
- Paper size : 75mm x 110mm
- Self generated suction system protects operator from harmful particles of paint and filler

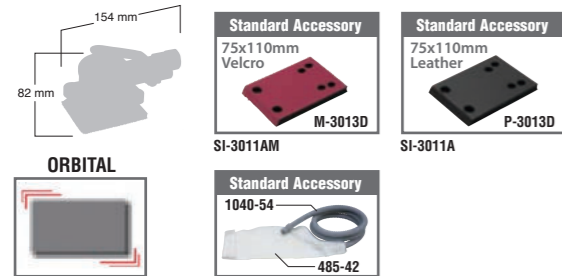

SI-3011AM

Self Vacuum Orbital Sander with velcro pad



Pad/Disc Size mm/(in.)	75x100
Orbit Dia mm	4
Free Speed r.p.m.	10,000
Out Put Watt	148
Weight kg/(lb)	1.15/(2.53)
Noise Level dBA/(power)	83/(94)
Vibration a/k m/s ²	7.4/1.5
Max Air Consumption CFM/(L/S)	15.0/(7.1)
Avg Air Consumption CFM/(L/S)	2.5/(1.2)

SI-3003A

Orbital Sander

- Palm grip orbital sander
- Paper size : 75mm x 110mm
- Powerful high quality air motor. 4mm orbit diameter

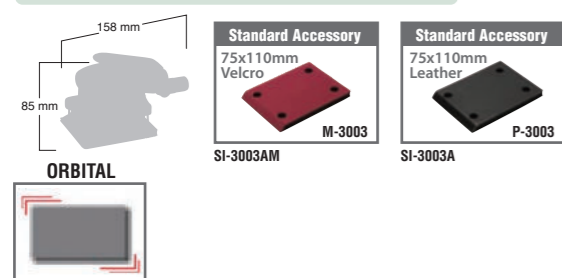

SI-3003AM

Orbital Sander with velcro pad



Pad/Disc Size mm/(in.)	75x100
Orbit Dia mm	4
Free Speed r.p.m.	9,000
Out Put Watt	134
Weight kg/(lb)	1.05/(2.31)
Noise Level dBA/(power)	75/(86)
Vibration a/k m/s ²	6.9/1.1
Max Air Consumption CFM/(L/S)	16.8/(7.9)
Avg Air Consumption CFM/(L/S)	2.8/(1.3)

SI-3005

Orbital Sander

- Bar grip orbital sander
- Paper size : 100mm x 180mm
- The tool has paper clips and you can use roll paper abrasive of 100mm width

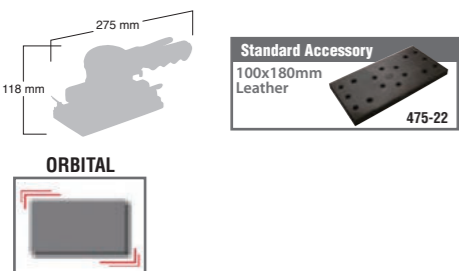

Pad/Disc Size mm/(in.)	90x165
Orbit Dia mm	5
Free Speed r.p.m.	11,000
Out Put Watt	289
Weight kg/(lb)	1.87/(4.13)
Noise Level dBA/(power)	88/(99)
Vibration a/k m/s ²	21.1/2.8
Max Air Consumption CFM/(L/S)	13.8/(6.5)
Avg Air Consumption CFM/(L/S)	2.3/(1.1)

SI-3007

Orbital Sander

- Paper size : 100mm x 180mm
- The tool has paper clips and you can use roll paper abrasive of 100mm width
- One hand grip for easy operation

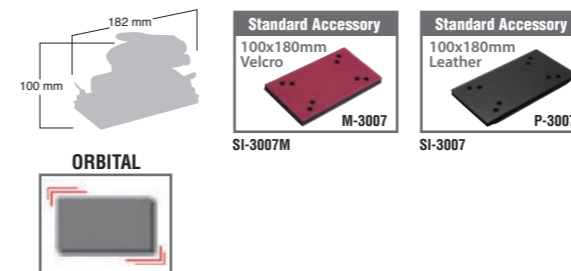

Pad/Disc Size mm/(in.)	95x175
Orbit Dia mm	5
Free Speed r.p.m.	11,000
Out Put Watt	275
Weight kg/(lb)	1.82/(4.00)
Noise Level dBA/(power)	86/(97)
Vibration a/k m/s ²	27.5/3.2
Max Air Consumption CFM/(L/S)	16.8/(7.9)
Avg Air Consumption CFM/(L/S)	2.8/(1.3)

SI-3018A

Self Vacuum Orbital Sander

- Self vacuum orbital sander with bar grip
- Paper size : 100mm x 180mm
- With leather pad or Velcro pad

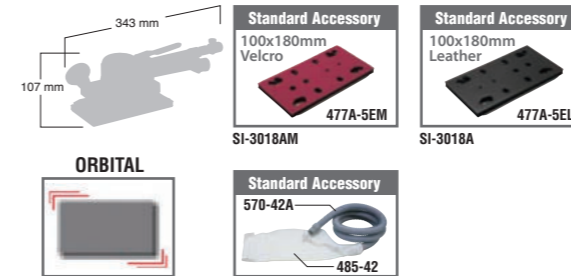

SI-3018AM

Self Vacuum Orbital Sander with velcro pad



Pad/Disc Size mm/(in.)	95x175
Orbit Dia mm	5
Free Speed r.p.m.	7,000
Out Put Watt	222
Weight kg/(lb)	2.31/(5.09)
Noise Level dBA/(power)	83/(94)
Vibration a/k m/s ²	10.2/1.5
Max Air Consumption CFM/(L/S)	18.6/(8.8)
Avg Air Consumption CFM/(L/S)	3.1/(1.5)

SI-3003B

Orbital Sander

- Light weight & heavyduty orbital sander
- Paper size : 75mm x 110mm

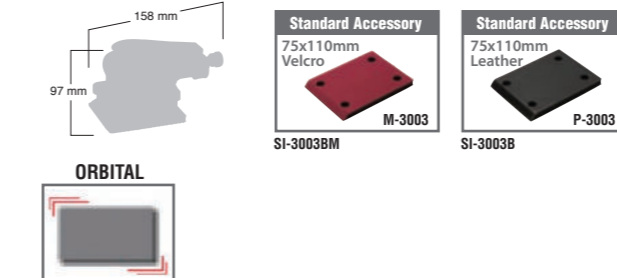

SI-3003BM

Orbital Sander with velcro pad



Heavy Duty Type

Pad/Disc Size mm/(in.)	75x100
Orbit Dia mm	4
Free Speed r.p.m.	8,000
Out Put Watt	134
Weight kg/(lb)	1.05/(2.31)
Noise Level dBA/(power)	88/(99)
Vibration a/k m/s ²	4.6/0.9
Max Air Consumption CFM/(L/S)	16.8/(7.9)
Avg Air Consumption CFM/(L/S)	2.8/(1.3)

SI-2026

Disc Sander



Pad/Disc Size mm/(in.)	125/(5")
Spindle Size	5/8-11UNC
Free Speed r.p.m.	5,500
Out Put Watt	491
Weight kg/(lb)	1.50/(3.31)
Noise Level dBA/(power)	88/(99)
Vibration a/k m/s ²	3.4/0.8
Max Air Consumption CFM/(L/S)	26.4/(12.5)
Avg Air Consumption CFM/(L/S)	4.4/(2.1)

SI-2351

Disc Sander



Pad/Disc Size mm/(in.)	180/(7")
Spindle Size	5/8-11UNC
Free Speed r.p.m.	4,500
Out Put Watt	458
Weight kg/(lb)	2.13/(4.70)
Noise Level dBA/(power)	80/(91)
Vibration a/k m/s ²	4.9/0.9
Max Air Consumption CFM/(L/S)	24.6/(11.6)
Avg Air Consumption CFM/(L/S)	4.1/(1.9)

SANDERS ACCESSORIES

SANDERS ACCESSORIES														
	5" Leather Pad 5/16-24UNF	5" Velcro Pad 5/16-24UNF	5" Leather Pad with 6holes 5/16-24UNF	5" Velcro Pad with 6holes 5/16-24UNF	6" Leather Pad 5/16-24UNF	6" Velcro Pad 5/16-24UNF	6" Leather Pad with 6holes 5/16-24UNF	6" Velcro Pad with 6holes 5/16-24UNF	6" Velcro Pad with 6holes 5/16-24UNF	6" Velcro Pad with 12holes 5/16-24UNF	6" Velcro Pad Face cover	6" Net Paper	ø19mm Dust Hose	ø25mm Dust Hose
SI-3121			★	☆									★	
SI-3121M			☆	★									★	
SI-3121-6								☆	☆	★	★	★	★	
SI-3101LG	★	☆												
SI-3101LGM	☆	★												
SI-3111LG			★	☆								★		★
SI-3111LGM			☆	★								★		★
SI-3101	★	☆	☆	☆										
SI-3101M	☆	★	☆	☆										
SI-3101-6					★	☆								
SI-3101-6M					☆	★								
SI-3111			★	☆								★		★
SI-3111M			☆	★								★		★
SI-3111-6							★	☆	☆			★		★
SI-3111-6M							☆	★	☆	☆		★		★
SI-3103A	★	☆	☆	☆										
SI-3103AM	☆	★	☆	☆										
SI-3103-6A					★	☆								
SI-3103-6AM					☆	★								
SI-3113A			★	☆									★	★
SI-3113AM			☆	★									★	★
SI-3113-6A						★	☆	☆					★	★
SI-3113-6AM						☆	★	☆	☆				★	★
SI-3118A			★	☆									★	★
SI-3118AM			☆	★									★	★
SI-3118-6A						★	☆	☆					★	★
SI-3118-6AM						☆	★	☆	☆				★	★
SI-3103B	★	☆	★	☆										
SI-3103BM	☆	★	☆	★										

★ : Standard ☆ : Option

SANDERS ACCESSORIES

SANDERS ACCESSORIES																					
	6" Velcro Pad 5/16-24UNF	6" Leather Pad 5/16-24UNF	5" Velcro Pad	6" Velcro Pad	3" Velcro Pad 5/16-24UNF	3" Velcro Pad with 3holes 5/16-24UNF	Leather Pad incl. Plate (490-588) No hole	Velcro Pad incl. Plate (490-588) No hole	Leather Pad incl. Plate (490-588) with hole	Velcro Pad incl. Plate (490-588) with hole	Leather Pad incl. Plate (477-44)	Velcro Pad incl. Plate (477-44)	Leather Pad incl. Plate 100x180	Velcro Pad incl 100x180	5" Back Disc	7" Back Disc	ø19mm Dust Hose	ø25mm Dust Hose	Dust Pack		
SI-3100	☆	★																			
SI-3100M	★	☆																			
SI-3115R			★																★	★	
SI-3115R-6				★															★	★	
SI-3102M					★																
SI-3112M						★													★	★	
SI-3001A							★	☆													
SI-3001AM							☆	★													
SI-3011A									★	☆									★	★	
SI-3011AM									☆	★									★	★	
SI-3003A							★	☆													
SI-3003AM							☆	★													
SI-3013									★	☆										★	★
SI-3013M									☆	★										★	★
SI-3005											★										
SI-3007												★	☆								
SI-3007M												☆	★								
SI-3018A														★	☆					★	★
SI-3018AM														☆	★					★	★
SI-3003B							★	☆													
SI-3003BM							☆	★													
SI-2026																★					
SI-2351																	★				

BELT SANDER ACCESSORIES																						
	Regulator	10mm Sanding belt #40	10mm Sanding belt #60	10mm Sanding belt #80	10mm Sanding belt #100	10mm Sanding belt #120	12mm Sanding belt #60	20mm Sanding belt #40	20mm Sanding belt #60	20mm Sanding belt #80	20mm Sanding belt #100	20mm Sanding belt #120	30mm Sanding belt #40	30mm Sanding belt #60	30mm Sanding belt #80	30mm Sanding belt #100	30mm Sanding belt #120	10mm Felt belt #60	10mm Felt belt #150	10mm Felt belt #320	13mm Sanding belt #60	
SI-2700	☆	☆	★	☆	☆	☆																
SI-2740	★	☆	★	☆	☆	☆																
SI-2741	★						★															
SI-2700L	☆																			★	★	★
SI-2700LS	☆																					★
SI-2800	☆							☆	★	☆	☆	☆	☆									
SI-2830	☆															★	☆	☆	☆			

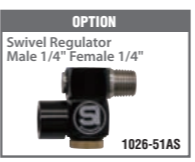

★ : Standard ☆ : Option

SI-2008EX

Heavy Duty Mini Sander

- Angle head sander with 2" pad. Light and compact. It is useful for sanding and polishing work at the narrow place

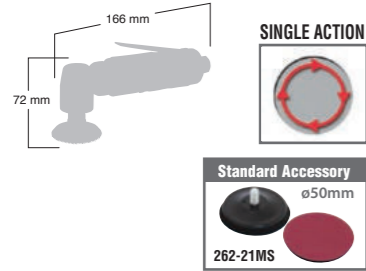

Pad/Disc Size mm/(in.)	50/(2")
Spindle Size	M6x1
Free Speed r.p.m.	14,500
Out Put Watt	175
Weight kg/(lb)	0.57/(1.26)
Noise Level dBA/(power)	83/(94)
Vibration a/k m/s ²	4.0/0.9
Max Air Consumption CFM/(L/S)	16.8/(7.9)
Avg Air Consumption CFM/(L/S)	2.8/(1.3)

SI-2107A

Mini Sander

- Angle head dual action sander with 2" Velcro pad
- You can use 2" sanding paper, wool buff or sponge buff
- A good tool for sanding and polishing where space is limited
- Dual action for easy operation and a good finish

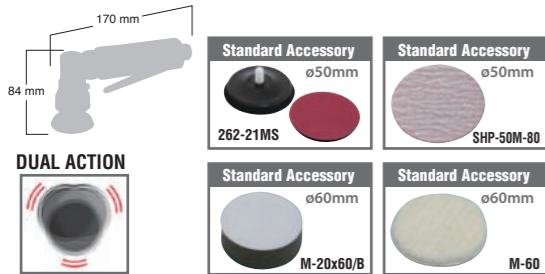

Pad/Disc Size mm/(in.)	50/(2")
Spindle Size	M6x1
Orbit Dia mm	3
Free Speed r.p.m.	14,000
Out Put Watt	127
Weight kg/(lb)	0.55/(1.20)
Noise Level dBA/(power)	85/(96)
Vibration a/k m/s ²	3.8/0.9
Max Air Consumption CFM/(L/S)	13.8/(6.5)
Avg Air Consumption CFM/(L/S)	2.3/(1.1)

SI-2108EX

Heavy Duty Mini Sander with 3" pad

- Angle head dual action sander with 3" pad.
- The high durable gears included for long time use.

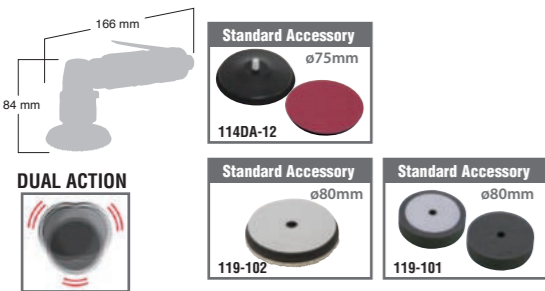

Pad/Disc Size mm/(in.)	75/(3")
Spindle Size	M6x1
Orbit Dia mm	3
Free Speed r.p.m.	15,500
Out Put Watt	175
Weight kg/(lb)	0.62/(1.36)
Noise Level dBA/(power)	85/(96)
Vibration a/k m/s ²	18.5/2.3
Max Air Consumption CFM/(L/S)	14.4/(6.8)
Avg Air Consumption CFM/(L/S)	2.4/(1.1)

SI-2108EX-2

Heavy Duty Mini Sander with 2" pad

- Angle head dual action sander with 2" pad.
- The high durable gears included for long time use.
- Great for sanding & polishing in confined spaces.

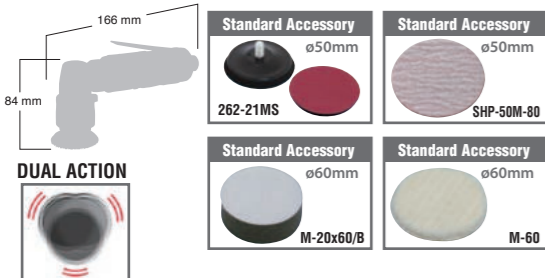

Pad/Disc Size mm/(in.)	50/(2")
Spindle Size	M6x1
Orbit Dia mm	3
Free Speed r.p.m.	15,500
Out Put Watt	175
Weight kg/(lb)	0.62/(1.36)
Noise Level dBA/(power)	85/(96)
Vibration a/k m/s ²	18.5/2.3
Max Air Consumption CFM/(L/S)	14.4/(6.8)
Avg Air Consumption CFM/(L/S)	2.4/(1.1)

SI-2210

Disc Sander

- A long seller in the market. Very popular high speed disc sander
- Easy one hand operation
- Disc inside dia.

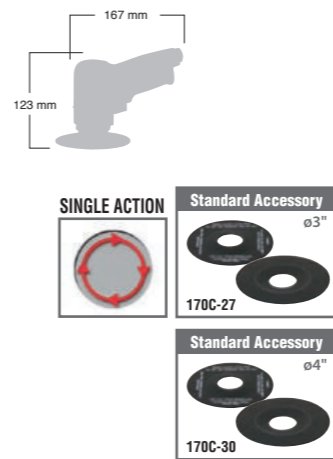

Pad/Disc Size mm/(in.)	75/(3")
Spindle Size	7/16-20UNF
Free Speed r.p.m.	19,000
Out Put Watt	475
Weight kg/(lb)	0.99/(2.17)
Noise Level dBA/(power)	91/(102)
Vibration a/k m/s ²	3.8/1.0
Max Air Consumption CFM/(L/S)	23.4/(11.0)
Avg Air Consumption CFM/(L/S)	3.9/(1.8)

SI-2201 Without Pad

Disc Sander

- Designed for direct mounting of the 3M Roloc Pad
- No adaptors necessary

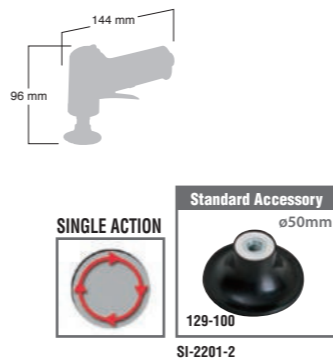

Pad/Disc Size mm/(in.)	50/(2")
Spindle Size	1/4-20UNC
Free Speed r.p.m.	17,000
Out Put Watt	174
Weight kg/(lb)	0.50/(1.10)
Noise Level dBA/(power)	82/(93)
Vibration a/k m/s ²	2.2/0.7
Max Air Consumption CFM/(L/S)	15.0/(7.1)
Avg Air Consumption CFM/(L/S)	2.5/(1.2)

SI-2202 without pad

Disc Sander

SI-2202-2 Disc Sander with 2" pad

Disc Sander with 2" pad

- Ideal for the removal of rust, surface deposits, and welds in hard-to-reach areas
- Double-sided, adjustable speed settings provide variability for a broader range of applications
- Designed for direct mounting of the 3M Roloc Pad



SI-2110S

Mini Dual Action Sander

- Engineered for the most aggressive sanding applications
- Durable ball-bearing construction ensures, a smooth power delivery

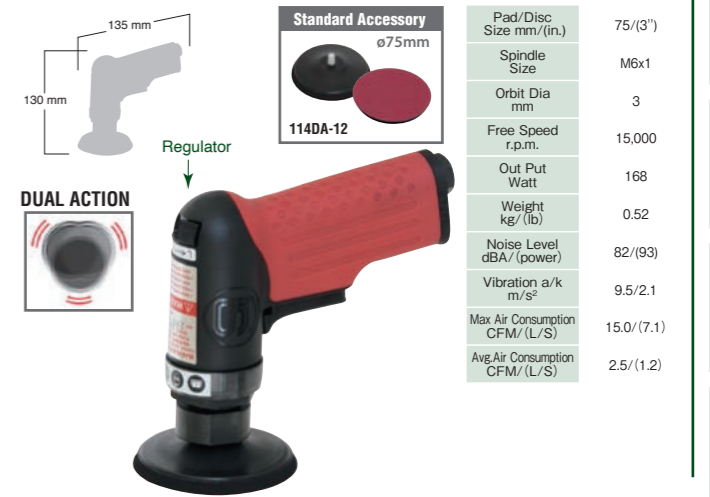

IMPACT WRENCHES
DRIVERS
RATCHET WRENCHES
SANDERS
POLISHERS
GRINDERS
DRILLS
SPOTLIGHTS
CUTTING TOOLS
OTHERS
INDUSTRIAL TOOLS
ACCESSORIES
SOUND & VIBRATION
MAINTENANCE CHECK
QUALITY

SI-2300

Disc Sander

- Vertical grip for stable and easy operation sander with 7" disc

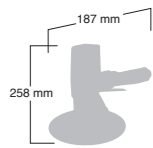

Pad/Disc Size mm/(in.)	180/(7")
Spindle Size	5/8-11UNC
Free Speed r.p.m.	4,000
Out Put Watt	409
Weight kg/(lb)	2.27/(5.01)
Noise Level dBA/(power)	82/(93)
Vibration a/k m/s ²	1.4/0.6
Max Air Consumption CFM/(L/S)	23.4/(11.0)
Avg Air Consumption CFM/(L/S)	3.9/(1.8)

SI-3200A

Oscillation Sander

- Self suck system protects operator from harmful powder of paint and filler
- Oscillating mechanism tool with a triangular pad. For delicate and fine sanding work
- Special designed oscillation sander for narrow place and corner

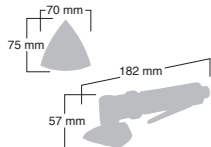

Pad/Disc Size mm/(in.)	△75x70
Spindle Size	M8x1.25
Oscillating Angle	2.8°
Free Speed o.p.m. ★	21,000
Out Put Watt	173
Weight kg/(lb)	0.65/(1.43)
Noise Level dBA/(power)	83/(94)
Vibration a/k m/s ²	9.6/2.2
Max Air Consumption CFM/(L/S)	14.4/(6.8)
Avg Air Consumption CFM/(L/S)	2.4/(1.1)

★o.p.m. (Oscillation Per Minutes)

SI-2322WR-LE

Wet Sanding Polisher lever switch

- Wet sander designed for stone sanding and polishing with water
- Supplied with 14mm thread spindle
- Waterproofed mechanism ensures a long working life
- Suitable for diamond polishing and dry marble polishing
- Water exits through spindle

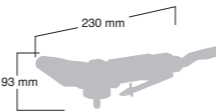

Pad/Disc Size mm/(in.)	φ80
Spindle Size	M14
Free Speed r.p.m.	5,500
Out Put Watt	435
Weight kg/(lb)	1.32/(2.91)
Noise Level dBA/(power)	88/(99)
Vibration a/k m/s ²	1.7/0.6
Max Air Consumption CFM/(L/S)	24.0/(11.3)
Avg Air Consumption CFM/(L/S)	4.0/(1.9)



SI-3310

Mini Orbital Finishing Sander

- Special design for the polishing of very small scratches, marks, bubble or dust on fresh paint surface.
- φ30mm diameter head can help you see the exact point to sand it can reduce buffing area.

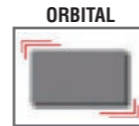
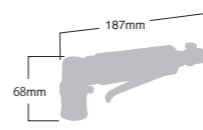

Pad/Disc Size mm/(in.)	φ30
Orbit Dia mm	3
Free Speed r.p.m.	10,000
Out Put Watt	127
Weight kg/(lb)	0.56/(1.23)
Noise Level dBA/(power)	83/(94)
Vibration a/k m/s ²	10.2/2.1
Max Air Consumption CFM/(L/S)	7.2/(3.4)
Avg Air Consumption CFM/(L/S)	1.2/(0.6)



SANDERS ACCESSORIES	MESP-65	262-21MS	SHP-50M-80	TZ-3000	114DA-12	M-20x60/B	M-60	119-101	119-102	170C-27	170C-30	820-52	129-100	118-3	115MB-6S	115MB-6H	1110A-80E
	φ65mm Sanding Disc	φ50mm Velcro Pad M6	φ30mm Sanding Paper	φ30mm Sanding Paper	φ75mm Velcro Pad M6	φ60mm Sponge Buff	φ60mm Wool Buff	φ80mm Sponge Buff	φ80mm Wool Buff	3" Disc Pad	4" Disc Pad	7" Back Disc	2" Disc Pad	Triangle Sanding Pad	φ30mm Soft Pad	φ30mm Hard Pad	φ80mm Velcro Pad (M14 P-2)
SI-2008EX	☆	★	☆			☆	☆										
SI-2107A		★	★			★	★										
SI-2108EX					★			★	★								
SI-2108EX-2		★	★			★	★										
SI-2210										★	☆						
SI-2201														☆			
SI-2201-2														★			
SI-2202														☆			
SI-2202-2														★			
SI-2110S					★												
SI-2300												★					
SI-3200A															★		
SI-2322WR-LE																	☆
SI-2322WR																	☆
SI-3310				★											★	★	







★ : Standard ☆ : Option

IMPACT WRENCHES
DRIVERS
RATCHET WRENCHES
SANDERS
POLISHERS
GRINDERS
DRILLS
SPOTLIGHTS
CUTTING TOOLS
OTHERS
INDUSTRIAL TOOLS
ACCESSORIES
SOUND & VIBRATION
MAINTENANCE CHECK
QUALITY



SHINANO INC. SANDER LINEUP

Work	Finish			
	Light	Orbital		Heavy
Non Vacuum	SI-3001A 	SI-3003A 	SI-3005 	SI-3003B 
Self Vacuum	SI-3011A 		SI-3018A 	
Non Vacuum			SI-3007 	





Work	Finish / Rough Finish
	Light
Non Vacuum	SI-3102M 
3 inch	
Self Vacuum	SI-3112M 

Work	Finish / Rough Finish				
	Light	Dual Action		Heavy	
5 inch	Non Vacuum	SI-3101 / SI-3101 LG 	SI-3103A 	SI-3118A 	SI-3103B 
	Self Vacuum	SI-3111 / SI-3111 LG 	SI-3113A 		
6 inch	Non Vacuum	SI-3101-6 	SI-3103-6A 	SI-3118-6A 	
	Self Vacuum	SI-3111-6 	SI-3113-6A 	SI-3100 	

Work	Finish / Rough Finish
	Light~Heavy
5 inch	Dual Action SI-3121 
	Central Vacuum SI-3121-6 
6 inch	

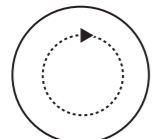
Work	Rough
	Heavy
5 inch	Geared Dual Action SI-3115R 
	Self Vacuum SI-3115R-6 
6 inch	

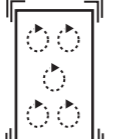
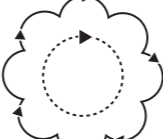
Sanding Mechanism

Name	Single Sander	Dual Action Sander	Orbital Sander	Geared Action Sander	Belt Sander
Pad type	Round type pad	Round type pad	Square pad	Round type pad	No pad
Movement					
Sanding Style	Single rotation	Double eccentric rotation	Eccentric rotation	Double eccentric rotation	Endless track for one side
Sanding Power	Strong	Little strong	Little Weak	Strong	Strong
Depth	Deep	Shallow	Shallow	Deep	Deep
work	•Peeling •Deburring	Coarse sanding for surface	Coarse & finish sanding for surface	Coarse sanding for surface	•Peeling •Deburring
Orbit Dia	Nothing	3mm~6mm	4mm~5mm	4.4mm	Nothing
SI Model	SI-2026,2351, 2210,2300, 2008,2210, etc	SI-3100,3101,3111,3121 3103A,3113A,3105A, 3118A,2107A,2108, etc	SI-3001A, 3018A,etc	SI-3115R,3115R-6	SI-2700,2700L, 2800,2830,2740 2700LS
					



SI-2415

POLISHERS

- GEARED DUAL ACTION POLISHER
- DUAL ACTION POLISHER
- SINGLE ACTION POLISHERS
- LIGHT SANDER POLISHER



POLISHERS

Geared Dual Action Polisher • Dual Action Polisher • Single Action Polishers

POLISHERS

Single Action Polishers • Light Sander Polisher

SI-2415

Geared Dual Action Polisher

- Geared polisher with 6" Velcro pad, 1,200r.p.m. low speed and high torque
- Designed for the wax polishing of painted motorcar body panels
- Either a wool buff or sponge buff can be used
- Geared dual action for easy operation

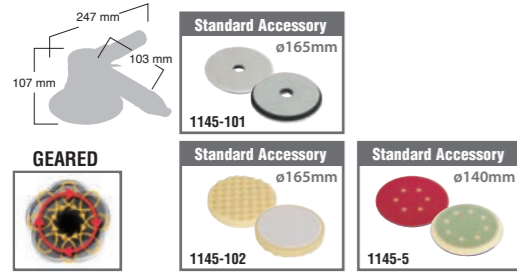

Buff Pad Size mm/(in.)	140/(6")
Orbit Dia mm	4.4
Free Speed r.p.m.	1,200
Weight kg/(lb)	1.45
Noise Level dBA/(power)	86/(97)
Vibration a/k m/s ²	13.1/5.6
Max Air Consumption CFM/(L/S)	20.4/(9.6)
Avg. Air Consumption CFM/(L/S)	3.4/(1.6)

SI-2009EX

Single Action Polisher

- Compact body design for reduce weight
- Low Speed Single Action Sander
- New design for 3" pad size



Buff Pad Size mm/(in.)	75/(3")
Spindle Size Female	5/16-24UNF
Free Speed r.p.m.	2,600
OutPut Watt	180
Weight kg/(lb)	0.68/(1.49)
Noise Level dBA/(power)	77/(88)
Vibration a/k m/s ²	1.1/0.6
Max Air Consumption CFM/(L/S)	15.0/(7.1)
Avg. Air Consumption CFM/(L/S)	2.5/(1.2)

SI-2009H

Single Action Polisher

- Compact body design for reduce weight
- High Speed Single Action Sander
- New design for 3" buff pad size



Buff Pad Size mm/(in.)	75/(3")
Spindle Size Female	5/16-24UNF
Free Speed r.p.m.	5,000
OutPut Watt	190
Weight kg/(lb)	0.68/(1.50)
Noise Level dBA/(power)	77/(88)
Vibration a/k m/s ²	2.3/0.7
Max Air Consumption CFM/(L/S)	12.6/(5.9)
Avg. Air Consumption CFM/(L/S)	2.1/(1.0)

SI-3100P

Dual Action Polisher

- Dual action polisher with 6" Velcro pad
- Designed for the wax polishing of painted motorcar body panel
- Either a wool buff or sponge buff can be used
- Uniform wax work with dual action
- Professional finish without special skill

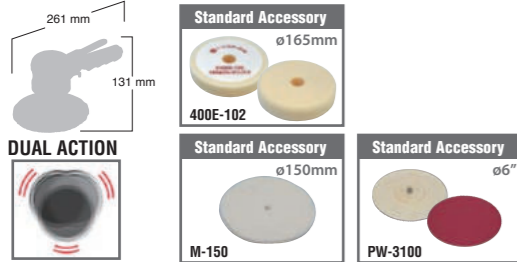

Buff Pad Size mm/(in.)	150/(6")
Spindle Size Female	5/16-24UNF
Orbit Dia mm	6
Free Speed r.p.m.	8,000
Out Put Watt	542
Weight kg/(lb)	1.81/(3.99)
Noise Level dBA/(power)	75/(86)
Vibration a/k m/s ²	6.7/3.1
Max Air Consumption CFM/(L/S)	13.8/(6.5)
Avg. Air Consumption CFM/(L/S)	2.3/(1.1)

SI-2400

Single Action Polisher



Buff Pad Size mm/(in.)	180/(7")
Spindle Size Male	5/8-11UNC
Free Speed r.p.m.	2,000
Out Put Watt	511
Weight kg/(lb)	2.24/(4.94)
Noise Level dBA/(power)	83/(94)
Vibration a/k m/s ²	1.8/0.6
Max Air Consumption CFM/(L/S)	24.0/(11.3)
Avg. Air Consumption CFM/(L/S)	4.0/(1.9)

SI-2405

Light Sander Polisher

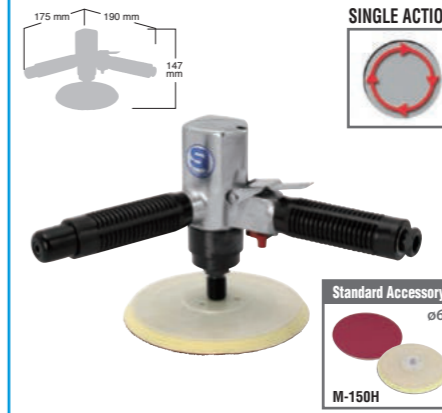

Buff Pad Size mm/(in.)	150/(6")
Spindle Size Female	5/16-24UNF
Free Speed r.p.m.	1,800
Out Put Watt	241
Weight kg/(lb)	1.17/(2.58)
Noise Level dBA/(power)	84/(95)
Vibration a/k m/s ²	1.8/1.0
Max Air Consumption CFM/(L/S)	16.8/(7.9)
Avg. Air Consumption CFM/(L/S)	2.8/(1.3)

SI-2451

Single Action Polisher



Buff Pad Size mm/(in.)	180/(7")
Spindle Size Male	5/8-11UNC
Free Speed r.p.m.	2,300
Out Put Watt	482
Weight kg/(lb)	2.13/(4.69)
Noise Level dBA/(power)	83/(94)
Vibration a/k m/s ²	2.2/0.7
Max Air Consumption CFM/(L/S)	23.4/(11.0)
Avg. Air Consumption CFM/(L/S)	3.9/(1.8)

SI-2221

Single Action Polisher

- Geared polisher with 3" Velcro pad
- Light and compact body
- Either a wool buff or sponge buff can be used
- Designed for Polishing and Buffing painted surface in confined areas
- The tool most suitable for repairing small scratch or dust on painted surfaces



Buff Pad Size mm/(in.)	75/(3")
Spindle Size Female	M6x1
Free Speed r.p.m.	4,500
Out Put Watt	203
Weight kg/(lb)	0.64/(1.42)
Noise Level dBA/(power)	83/(94)
Vibration a/k m/s ²	1.4/0.6
Max Air Consumption CFM/(L/S)	15.0/(7.1)
Avg. Air Consumption CFM/(L/S)	2.5/(1.2)

SI-2224S

Single Action Polisher

- Geared polisher with 3" Velcro pad
- Super light weight & compact design with solid composite body
- Based on two-layer molded rubber grip giving comfortable grip and reducing vibration

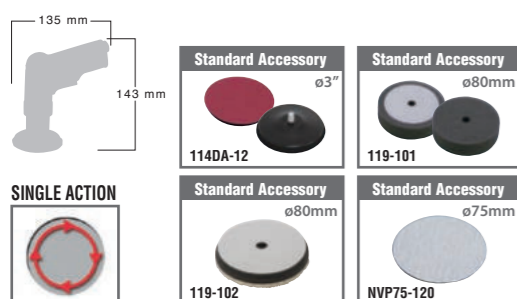

Buff Pad Size mm/(in.)	75/(3")
Spindle Size Female	M6x1
Free Speed r.p.m.	5,000
Out Put Watt	270
Weight kg/(lb)	0.60/(1.32)
Noise Level dBA/(power)	83/(94)
Vibration a/k m/s ²	1.6/0.6
Max Air Consumption CFM/(L/S)	15.0/(7.1)
Avg. Air Consumption CFM/(L/S)	2.5/(1.2)

POLISHERS ACCESSORIES	M-150H	114DA-12	400E-102	M-150	M-75H	119-101	119-102	NVP75-120	1145-101	1145-102	1145-5	820-52	PW-3100
SI-2415									★	★	★		
SI-3100P													★
SI-2221													
SI-2224S		★											
SI-2009EX					★	★	★	★					
SI-2009H					★	★	★						
SI-2400													★
SI-2405	★												
SI-2451													★

★ : Standard ☆ : Option

IMPACT WRENCHES
DRIVERS
RATCHET WRENCHES
SANDERS
POLISHERS
GRINDERS
DRILLS SPOTLIGHTS
CUTTING TOOLS
OTHERS
INDUSTRIAL TOOLS
ACCESSORIES
SOUND & VIBRATION
MAINTENANCE CHECK
QUALITY



SI-2520L

GRINDERS

DIE GRINDERS
CUT OFF GRINDER
DISC GRINDERS
MICRO GRINDERS
WET GRINDER

GRINDERS Die Grinders

SI-2001S Die Grinder SI-2001S-6 6mm Collet model

- Small body size die grinder
- 1/4" collet and 6mm collets are available

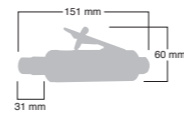

Collet Size	ø1/4"
	ø6mm
Free Speed r.p.m. (MAX)	25,000
Output Watt	173
Weight kg/ (lb)	0.37/(0.82)
Noise Level dBA/ (power)	84/(95)
Vibration a/k m/s ²	3.4/0.8
Max Air Consumption CFM/ (L/S)	16.2/(7.6)
Avg Air Consumption CFM/ (L/S)	2.7/(1.3)

SI-2002EX Die Grinder SI-2002EX-6 6mm Collet model

- Compact, lightweight, ergonomic design
- Double mold composite body cover for added vibration and cold temperature protection
- 1/4" collet and 6mm collets are available

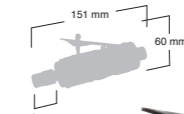

Collet Size	ø1/4"
	ø6mm
Free Speed r.p.m. (MAX)	27,000
Output Watt	219
Weight kg/ (lb)	0.37/(0.83)
Noise Level dBA/ (power)	84/(95)
Vibration a/k m/s ²	2.3/0.7
Max Air Consumption CFM/ (L/S)	15.6/(7.4)
Avg Air Consumption CFM/ (L/S)	2.6/(1.2)

SI-2011S Die Grinder SI-2011S-6 6mm Collet model

- Medium body size die grinder
- 1/4" collet and 6mm collets are available
- Rear exhaust directs air away from operator and work place
- Lever throttle with safety lock
- Compact, lightweight, ergonomic design and feather touch throttle lever for easy operation

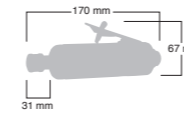

Collet Size	ø1/4"
	ø6mm
Free Speed r.p.m. (MAX)	25,000
Output Watt	422
Weight kg/ (lb)	0.60/(1.32)
Noise Level dBA/ (power)	87/(98)
Vibration a/k m/s ²	6.5/1.1
Max Air Consumption CFM/ (L/S)	24.0/(11.3)
Avg Air Consumption CFM/ (L/S)	4.0/(1.9)

SI-2012EX Die Grinder SI-2012EX-6 6mm Collet model

- Medium body size die grinder
- 1/4" collet and 6mm collets are available
- Compact, lightweight, ergonomic design and feather touch throttle lever
- Double mold composite body cover for added vibration and cold temperature protection

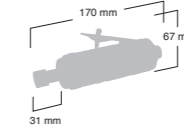

Collet Size	ø1/4"
	ø6mm
Free Speed r.p.m. (MAX)	25,000
Output Watt	388
Weight kg/ (lb)	0.60/(1.31)
Noise Level dBA/ (power)	87/(98)
Vibration a/k m/s ²	3.9/1.3
Max Air Consumption CFM/ (L/S)	24.0/(11.3)
Avg Air Consumption CFM/ (L/S)	4.0/(1.9)

SI-2015A Die Grinder SI-2015A-6 6mm Collet model

- Planetary geared die grinder. 5,500r.p.m. low speed and high torque
- 1/4" and 6mm collets are available
- Compact, lightweight, ergonomic design and feather touch throttle lever for easy operation
- A plastic body cover absorbs tool vibrations and protects your hand from the cold

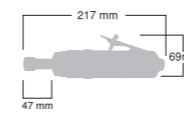

Collet Size	ø1/4"
	ø6mm
Free Speed r.p.m. (MAX)	5,500
Output Watt	457
Weight kg/ (lb)	0.91/(2.01)
Noise Level dBA/ (power)	88/(99)
Vibration a/k m/s ²	4.9/0.9
Max Air Consumption CFM/ (L/S)	25.2/(11.9)
Avg Air Consumption CFM/ (L/S)	4.2/(2.0)

SI-2010 Die Grinder SI-2010-6 6mm Collet model

- Compact, lightweight, ergonomic design and feather touch throttle lever for easy operation
- A plastic body cover absorbs tool vibrations and protects your hand from the cold

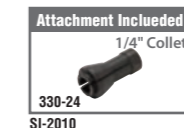
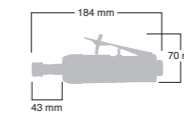

Collet Size	ø1/4"
	ø6mm
Free Speed r.p.m. (MAX)	23,000
Output Watt	247
Weight kg/ (lb)	0.52/(1.14)
Noise Level dBA/ (power)	83/(94)
Vibration a/k m/s ²	5.9/1.0
Max Air Consumption CFM/ (L/S)	10.8/(5.1)
Avg Air Consumption CFM/ (L/S)	1.8/(0.8)

IMPACT WRENCHES
DRIVERS
RATCHET WRENCHES
SANDERS
POLISHERS
GRINDERS
DRILLS
SPOTLIGHTS
CUTTING TOOLS
OTHERS
INDUSTRIAL TOOLS
ACCESSORIES
SOUND & VIBRATION
MAINTENANCE CHECK
QUALITY

GRINDERS Die Grinders • Cut off Grinder

SI-2005HD Die Grinder

- Small body size, angle head die grinder with a polymer grip cover
- High durability die grinder
- Compact, lightweight, ergonomic design and feather touch throttle lever for easy operation.
- A plastic body cover absorbs tool vibrations and protects your hand from the cold
- Lever throttle with safety lock

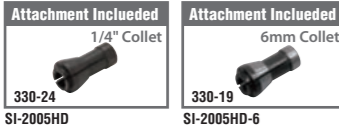
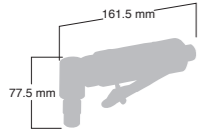

SI-2005HD-6 Die Grinder 6mm Collet model



	SI-2005HD	SI-2005HD-6
Collet Size	ø1/4"	ø6mm
Free Speed r.p.m. (MAX)	20,000	20,000
Output Watt	200	200
Weight kg/(lb)	0.56/(1.23)	0.56/(1.23)
Noise Level dBA/(power)	81/(92)	81/(92)
Vibration a/k m/s ²	7.3/1.2	7.3/1.2
Max Air Consumption CFM/(L/S)	14.4/(6.8)	14.4/(6.8)
Avg Air Consumption CFM/(L/S)	2.4/(1.1)	2.4/(1.1)

SI-2006S Die Grinder

- Small body size, angle head die grinder
- 1/4" collet and 6mm collets are available
- Compact, lightweight, ergonomic design and feather touch throttle lever for easy operation
- Lever throttle with safety lock

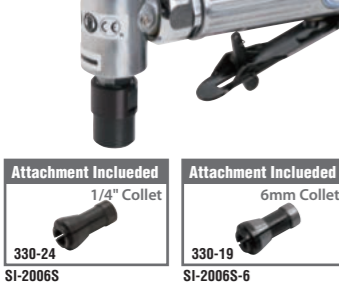
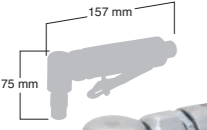

SI-2006S-6 Die Grinder 6mm Collet model

	SI-2006S	SI-2006S-6
Collet Size	ø1/4"	ø6mm
Free Speed r.p.m. (MAX)	20,000	20,000
Output Watt	127	127
Weight kg/(lb)	0.49/(1.08)	0.49/(1.08)
Noise Level dBA/(power)	83/(94)	83/(94)
Vibration a/k m/s ²	7.4/1.6	7.4/1.6
Max Air Consumption CFM/(L/S)	13.8/(6.5)	13.8/(6.5)
Avg Air Consumption CFM/(L/S)	2.3/(1.1)	2.3/(1.1)

SI-2033 Cut off Grinder

- A straight grinder designed for 3" cut off discs
- For cutting sheet metal or pipe
- Especially useful for cutting the exhaust pipe on motorcars
- Compact and lightweight body with lever throttle for safety operation

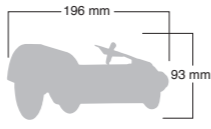

SI-2023 Die Grinder

- Die grinder with the extended shaft
- 1/4" collet and 6mm collets are available
- Special designed extended die grinder for unreachable place

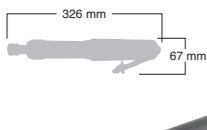

SI-2023S-6 Die Grinder 6mm Collet model

	SI-2023S	SI-2023S-6
Collet Size	ø1/4"	ø6mm
Free Speed r.p.m. (MAX)	24,000	24,000
Output Watt	537	537
Weight kg/(lb)	1.34/(2.94)	1.34/(2.94)
Noise Level dBA/(power)	89/(100)	89/(100)
Vibration a/k m/s ²	4.1/0.9	4.1/0.9
Max Air Consumption CFM/(L/S)	27.0/(12.7)	27.0/(12.7)
Avg Air Consumption CFM/(L/S)	4.5/(2.1)	4.5/(2.1)

SI-2023 Die Grinder

- Low Speed Die Grinder
- 1/4" collet and 6mm collets are available
- Sander with the extended shaft
- Special designed extended Sander for unreachable place

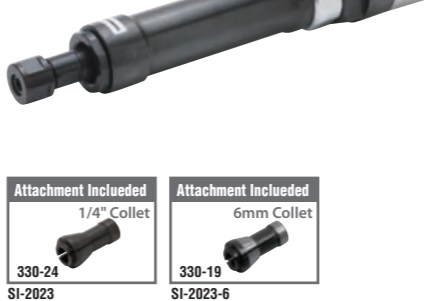
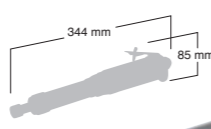

SI-2023-6 Die Grinder 6mm Collet model

	SI-2023	SI-2023-6
Collet Size	ø1/4"	ø6mm
Free Speed r.p.m. (MAX)	6,000	6,000
Output Watt	435	435
Weight kg/(lb)	1.70/(3.75)	1.70/(3.75)
Noise Level dBA/(power)	90/(101)	90/(101)
Vibration a/k m/s ²	4.0/0.9	4.0/0.9
Max Air Consumption CFM/(L/S)	22.8/(10.8)	22.8/(10.8)
Avg Air Consumption CFM/(L/S)	3.8/(1.9)	3.8/(1.9)

GRINDERS Disc Grinders

SI-2501L Disc Grinder Lever Switch

- Light weight 4" disc grinder with rotary throttle
- 40% lighter than SI-2500
- Speed governor assures safety operation
- Precise gear mechanism assures the highest power transfer, durability and reduced vibration

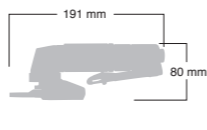

SI-2501 Disc Grinder Rotary Switch

	SI-2501	SI-2501L
Disc Size mm/(in.)	100/(4")	100/(4")
Spindle Size	M10x1.5	M10x1.5
Free Speed r.p.m. (MAX)	13,000	13,000
Output Watt	303	303
Weight kg/(lb)	1.04/(2.29)	0.91/(2.01)
Noise Level dBA/(power)	81/(92)	82/(93)
Vibration a/k m/s ²	9.6/3.1	8.4/2.8
Max Air Consumption CFM/(L/S)	16.2/(7.6)	13.2/(6.2)
Avg Air Consumption CFM/(L/S)	2.7/(1.3)	2.2/(1.0)

SI-2500L Disc Grinder Lever Switch

- The high quality air motor used ensures the highest power and durability, while reducing vibration
- A trouble free tool for industry use

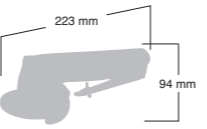

SI-2500 Disc Grinder Rotary Switch

	SI-2500L	SI-2500
Disc Size mm/(in.)	100/(4")	100/(4")
Spindle Size	M10x1.5	M10x1.5
Free Speed r.p.m. (MAX)	12,700	12,700
Output Watt	443	443
Weight kg/(lb)	1.82/(4.02)	1.87/(4.11)
Noise Level dBA/(power)	80/(91)	84/(95)
Vibration a/k m/s ²	9.9/3.2	7.6/2.5
Max Air Consumption CFM/(L/S)	16.2/(7.6)	14.4/(6.8)
Avg Air Consumption CFM/(L/S)	2.7/(1.3)	2.4/(1.1)

SI-2515LA Disc Grinder

- 5" Disc grinder with safety lever throttle and 14mm thread spindle
- Speed governor assures safety operation
- Spindle lock button enable exchanging disc quickly
- Rear exhaust and lever throttle with safety lock
- Disc one push lock button model

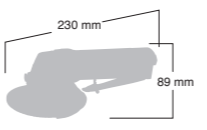

Disc Size mm/(in.)	125/(5")
Spindle Size	M14x2
Free Speed r.p.m. (MAX)	12,000
Output Watt	570
Weight kg/(lb)	1.93/(4.27)
Noise Level dBA/(power)	85/(96)
Vibration a/k m/s ²	11.0/3.6
Max Air Consumption CFM/(L/S)	16.8/(7.9)
Avg Air Consumption CFM/(L/S)	2.8/(1.3)

SI-2505L Disc Grinder

- 5" Disc grinder with safety lever throttle
- For this model because of the safety reason
- Speed governor assures safety operation
- Lever throttle with safety lock

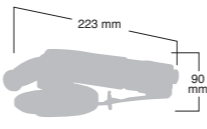

Disc Size mm/(in.)	125/(5")
Disc Hole Size	ø22/(7/8")
Free Speed r.p.m. (MAX)	12,000
Output Watt	443
Weight kg/(lb)	1.91/(4.22)
Noise Level dBA/(power)	82/(93)
Vibration a/k m/s ²	5.8/1.9
Max Air Consumption CFM/(L/S)	19.8/(9.3)
Avg Air Consumption CFM/(L/S)	3.3/(1.6)

SI-2520L New 5" Angle Disc Grinder

- 5" Disc grinder with safety lever throttle and 14mm thread spindle.
- Speed governor assures safety operation.
- Spindle lock button enable exchanging disc quickly.
- Disc cover is easy to change the disc cover position.
- 105 Degrees for comfortable operation.
- Composite housing prevents cold hands even if you works long time.

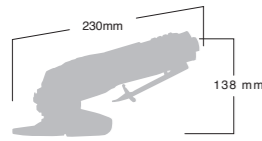

Disc Size mm/(in.)	125/(5")
Spindle Size	M14x2
Free Speed r.p.m. (MAX)	12,000
Output Watt	610
Weight kg/(lb)	1.85/(4.07)
Noise Level dBA/(power)	76.4/(87.4)
Vibration a/k m/s ²	1.56/(0.51)
Max Air Consumption CFM/(L/S)	16.8/(7.8)
Avg Air Consumption CFM/(L/S)	2.8/(1.3)



Option

247-25 Exhaust Hose 50cm

106-3 Wipe Hose 1.35m

Adjustable disc cover



Side View



SI-2515WE Wet Grinder

- Heavy duty rear exhaust wet grinder for use with 5" disc & diamond cup wheels
- Include air hose, water hose and wrenches
- Waterproof mechanism ensure a long working life

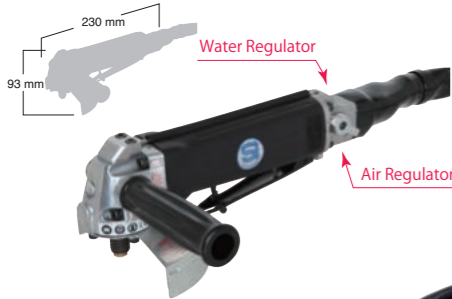

Disc Size mm/(in.)	125/(5")
Spindle Size	M14x2
Free Speed r.p.m. (MAX)	10,000
Output Watt	570
Weight kg/(lb)	2.01/(4.43)
Noise Level dBA/(power)	85/(96)
Vibration a/k m/s ²	11.0/3.6
Max Air Consumption CFM/(L/S)	16.8/(7.9)
Avg Air Consumption CFM/(L/S)	2.8/(1.3)



1.5m Air-line
7.5m Water-line

SI-2600L Disc Grinder

- 7" Disc grinder with safety lever throttle
- Speed governor assures safety operation
- High quality air motor assures high power, durability, reducing vibration and trouble free use

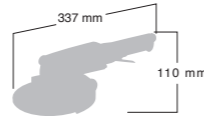

Disc Size mm/(in.)	180/(7")
Disc Hole Size	M10x1.5
Free Speed r.p.m. (MAX)	7,500
Output Watt	754
Weight kg/(lb)	3.24/(7.15)
Noise Level dBA/(power)	97/(108)
Vibration a/k m/s ²	4.0/1.3
Max Air Consumption CFM/(L/S)	24.0/(11.3)
Avg Air Consumption CFM/(L/S)	4.0/(1.9)



SI-2050AG Micro Grinder

- High speed angle head disc grinder with 30mm diameter disc
- 21,000r.p.m.
- For exact and delicate work

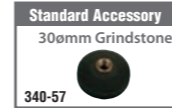

Disc Size mm/(in.)	ø30
Spindle Size	M7x0.75
Free Speed r.p.m. (MAX)	21,000
Weight kg/(lb)	0.23/(0.52)
Noise Level dBA/(power)	71/(82)
Vibration a/k m/s ²	0.9/0.3
Max Air Consumption CFM/(L/S)	6.6/(3.1)
Avg Air Consumption CFM/(L/S)	1.1/(0.5)



SI-2051SG Micro Grinder

- High speed die grinder with 3mm or 1/8" collet
- Low vibration and noise allows extended use
- Option : 1/8" Dia collet

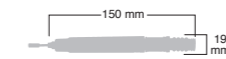

Collet Size	ø3 , 1/8"
Free Speed r.p.m. (MAX)	50,000
Weight kg/(lb)	0.19/(0.43)
Noise Level dBA/(power)	71/(82)
Vibration a/k m/s ²	1.2/0.6
Max Air Consumption CFM/(L/S)	6.0/(2.8)
Avg Air Consumption CFM/(L/S)	1.0/(0.5)



GRINDERS ACCESSORIES	330-24	330-19	330-25	330-26	210-5-1A	175-29	240-6	240-71	240C-1	380-44	241-49	280-28	340-57	340-2A	340-2B	340-55
	1/4" Collet	6mm Collet	1/8" Collet	3mm Collet	Dead handle set	3"Cut Disc	4"Disc 15mm Hole	4"Disc 16mm Hole	Disc Nut for 16mm Hole	Disc Nut for 15mm Hole	5"Disc	7"Disc	30mm Grindstone	3mm Collet	1/8" Collet	ø5mm Grindstone (3mm)
SI-2001S	★	☆	☆	☆												
SI-2001S-6	☆	★	☆	☆												
SI-2002EX	★	☆	☆	☆												
SI-2002EX-6	☆	★	☆	☆												
SI-2011S	★	☆	☆	☆												
SI-2011S-6	☆	★	☆	☆												
SI-2012EX	★	☆	☆	☆												
SI-2012EX-6	☆	★	☆	☆												
SI-2015A	★	☆	☆	☆												
SI-2015A-6	☆	★	☆	☆												
SI-2010	★	☆	☆	☆												
SI-2010-6	☆	★	☆	☆												
SI-2005HD	★	☆	☆	☆												
SI-2005HD-6	☆	★	☆	☆												
SI-2006S	★	☆	☆	☆												
SI-2006S-6	☆	★	☆	☆												
SI-2033						★										
SI-2022S	★	☆	☆	☆												
SI-2022S-6	☆	★	☆	☆												
SI-2023	★	☆	☆	☆												
SI-2023-6	☆	★	☆	☆												
SI-2501L								☆	★	★	☆					
SI-2501								★	☆	☆	★					
SI-2500L								☆	★	★	☆					
SI-2500								☆	★	★	☆					
SI-2515LA												★				
SI-2520L												★				
SI-2505L												★				
SI-2600L													★			
SI-2050AG																★
SI-2051SG															★	★

★ : Standard ☆ : Option

IMPACT WRENCHES
DRIVERS
RATCHET WRENCHES
SANDERS
POLISHERS
GRINDERS
DRILLS SPOTDRILLS
CUTTING TOOLS
OTHERS
INDUSTRIAL TOOLS
ACCESSORIES
SOUND & VIBRATION
MAINTENANCE CHECK
QUALITY



SI-5405-6

DRILLS / SPOT MILLS

DRILLS
SPOT MILLS



DRILLS / SPOT MILLS Drills

SI-2015AD Drill

- 3/8" capacity geared straight grip drill
- Specially designed tool for use in narrow place

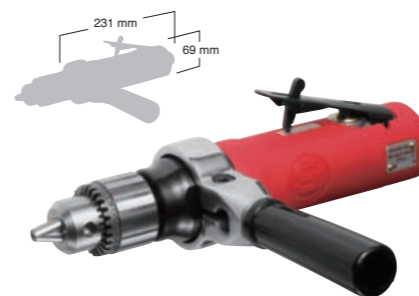

Free Speed r.p.m.	6,000
Chuck Size mm/(in.)	10/(3/8)
Spindle Size	3/8-24UNF
Drilling Cap mm/(in.)	6/(1/4)
Out Put Watt	457
Max Torque Nm/(ft-lb)	2.62/(1.92)
Weight kg/(lb)	1.06/(2.34)
Noise Level dBA/(power)	86/(97)
Vibration a/k m/s ²	2.6/0.7
Max Air Consumption CFM/(L/S)	25.2/(11.9)
Avg Air Consumption CFM/(L/S)	4.2/(2.0)



SI-5100A Drill

- 3/8" capacity geared pistol grip drill
- High speed drill for soft metal



Free Speed r.p.m.	5,000
Chuck Size mm/(in.)	10/(3/8)
Spindle Size	3/8-24UNF
Drilling Cap mm/(in.)	6/(1/4)
Out Put Watt	390
Max Torque Nm/(ft-lb)	3.06/(2.24)
Weight kg/(lb)	0.90/(1.99)
Noise Level dBA/(power)	84/(95)
Vibration a/k m/s ²	3.4/0.8
Max Air Consumption CFM/(L/S)	19.8/(9.3)
Avg Air Consumption CFM/(L/S)	3.3/(1.6)



SI-5200A Drill

- 1/2" capacity, geared, pistol grip drill
- 600r.p.m. low speed and high torque
- Ergonomic, compact, lightweight design with feather touch trigger for easy drill bit centering
- Precise planetary gear mechanism with needle roller assures high power, durability and reducing vibration
- Side handle for greater hand grip and control for easy operation



Free Speed r.p.m.	600
Chuck Size mm/(in.)	13/(1/2)
Spindle Size	3/8-24UNF
Drilling Cap mm/(in.)	13/(1/2)
Out Put Watt	390
Max Torque Nm/(ft-lb)	16.81/(12.40)
Weight kg/(lb)	1.42/(3.12)
Noise Level dBA/(power)	82/(93)
Vibration a/k m/s ²	3.0/1.0
Max Air Consumption CFM/(L/S)	21.0/(9.9)
Avg Air Consumption CFM/(L/S)	3.5/(1.6)



SI-5300A Drill

- 3/8" capacity geared pistol grip drill
- Heavy duty and the best selling model of the drills
- Precise planetary gear mechanism with needle roller assures high power, durability and reducing vibration
- Ergonomic, compact, lightweight design with feather touch trigger for easy centering



Free Speed r.p.m.	2,000
Chuck Size mm/(in.)	10/(3/8)
Spindle Size	3/8-24UNF
Drilling Cap mm/(in.)	10/(3/8)
Out Put Watt	378
Max Torque Nm/(ft-lb)	6.32/(4.64)
Weight kg/(lb)	0.91/(2.01)
Noise Level dBA/(power)	84/(95)
Vibration a/k m/s ²	2.0/0.7
Max Air Consumption CFM/(L/S)	21.6/(10.2)
Avg Air Consumption CFM/(L/S)	3.6/(1.7)



SI-5305A Reversible Drill

- 3/8" capacity geared pistol grip reversible drill
- Handy reverse mechanism
- Can be used for tapping work by utilizing the reverse function



Free Speed r.p.m.	2,000
Chuck Size mm/(in.)	10/(3/8)
Spindle Size	3/8-24UNF
Drilling Cap mm/(in.)	10/(3/8)
Out Put Watt	326
Max Torque Nm/(ft-lb)	F 5.24/(3.85) R 5.71/(4.19)
Weight kg/(lb)	1.02/(2.24)
Noise Level dBA/(power)	90/(101)
Vibration a/k m/s ²	4.7/0.9
Max Air Consumption CFM/(L/S)	23.4/(11.0)
Avg Air Consumption CFM/(L/S)	3.9/(1.8)



SI-5305-8A Reversible Drill

- 1/2" capacity geared pistol grip reversible drill. 800r.p.m. low speed and high torque.
- Handy reverse mechanism
- Can be used for tapping work by utilizing the reverse function
- Side handle for greater hand grip and control for easy operation



Free Speed r.p.m.	800
Chuck Size mm/(in.)	13/(1/2)
Spindle Size	3/8-24UNF
Drilling Cap mm/(in.)	13/(1/2)
Out Put Watt	326
Max Torque Nm/(ft-lb)	11.66/(8.60)
Weight kg/(lb)	1.45/(3.20)
Noise Level dBA/(power)	91/(102)
Vibration a/k m/s ²	6.0/1.6
Max Air Consumption CFM/(L/S)	25.2/(11.9)
Avg Air Consumption CFM/(L/S)	4.2/(2.0)



IMPACT
WRENCHES
DRIVERS
RATCHET
WRENCHES
SCREWDRIVERS
POLISHERS
GRINDERS
DRILLS
SPOTMILLS
CUTTING TOOLS
OTHERS
INDUSTRIAL
TOOLS
ACCESSORIES
SOUND &
VIBRATION
MAINTENANCE
CHECK
QUALITY

SI-5501 Drill SI-5506 Reversible Drill

- Super light weight & compact design with solid composite body
- Based on two-layer molded rubber grip giving comfortable grip and reducing vibration
- 3/8" capacity geared pistol grip drill
- A swivel lever for regulator can be used with one hand allowing easy operation

SI-5501 **SI-5506**

Free Speed r.p.m.	2,400	1,700
Chuck Size mm/(in.)	10/(3/8)	10/(3/8)
Spindle Size	3/8-24UNF	3/8-24UNF
Drilling Cap mm/(in.)	10/(3/8)	10/(3/8)
Out Put Watt	234	146
Max Torque Nm/(ft-lb)	3.80/(2.79)	F 2.67/(1.96) R 2.58/(1.89)
Weight kg/(lb)	0.60/(1.32)	0.60/(1.32)
Noise Level dBA/(power)	80/(91)	80/(91)
Vibration a/k m/s ²	2.6/0.7	1.9/0.6
Max Air Consumption CFM/(L/S)	13.2/(6.2)	14.4/(6.8)
Avg Air Consumption CFM/(L/S)	2.2/(1.0)	2.4/(1.1)

Standard Accessory
Chuck Handle
KD-002 (3/8" Drill Chuck w/Handle KG1)
SI-5506 Reverse Lever

SI-5355 Angle Head Drill

- 3/8" capacity geared angle head drill
- Designed to facilitate drilling in confined places

SI-5355

Free Speed r.p.m.	1,200
Chuck Size mm/(in.)	10/(3/8)
Spindle Size	3/8-24UNF
Drilling Cap mm/(in.)	10/(3/8)
Out Put Watt	180
Max Torque Nm/(ft-lb)	F 4.54/(3.37) R 4.37/(3.21)
Weight kg/(lb)	0.94/(2.07)
Noise Level dBA/(power)	84/(95)
Vibration a/k m/s ²	3.2/0.8
Max Air Consumption CFM/(L/S)	18.0/(8.5)
Avg Air Consumption CFM/(L/S)	3.0/(1.4)

Standard Accessory
Chuck Handle
KD-004 (3/8" Drill Chuck w/Handle KK)

SI-5405 Reversible Drill

- Triple idler planetary gearing for smooth operation and extended tool life.
- Body end mounted reverse lever for one hand directional changes.
- High quality 3/8" chuck.

SI-5405

Free Speed r.p.m.	1,500
Chuck Size mm/(in.)	10/(3/8)
Spindle Size	3/8-24UNF
Drilling Cap mm/(in.)	10/(3/8)
Out Put Watt	197
Max Torque Nm/(ft-lb)	F 4.83/(3.55) R 4.70/(3.45)
Weight kg/(lb)	1.08/(2.38)
Noise Level dBA/(power)	80/(91)
Vibration a/k m/s ²	2.9/0.9
Max Air Consumption CFM/(L/S)	14.4/(6.8)
Avg Air Consumption CFM/(L/S)	2.4/(1.1)

Standard Accessory
(Yukiwa)
LX10

SI-5405-6 Reversible Drill

- Side handle assures easy operation and prevent wrist from injuries.
- Double reduction mechanism for exceptional power.
- 1/2" capacity standard rated grill chuck.

SI-5405-6

Free Speed r.p.m.	600
Chuck Size mm/(in.)	13/(1/2)
Spindle Size	3/8-24UNF
Drilling Cap mm/(in.)	13/(1/2)
Out Put Watt	186
Max Torque Nm/(ft-lb)	10.58/(7.80)
Weight kg/(lb)	1.41/(3.10)
Noise Level dBA/(power)	82/(93)
Vibration a/k m/s ²	3.4/0.8
Max Air Consumption CFM/(L/S)	13.8/(6.5)
Avg Air Consumption CFM/(L/S)	2.3/(1.1)

Standard Accessory
(Yukiwa)
LM13W
210-5-1A

SI-5500 Drill

- 3/8" capacity geared pistol grip drill
- Light duty and reasonable price model
- Ergonomic, compact and lightweight design for easy operation

SI-5500

Free Speed r.p.m.	2,600
Chuck Size mm/(in.)	10/(3/8)
Spindle Size	3/8-24UNF
Drilling Cap mm/(in.)	10/(3/8)
Out Put Watt	258
Max Torque Nm/(ft-lb)	3.54/(2.53)
Weight kg/(lb)	0.79/(1.75)
Noise Level dBA/(power)	85/(96)
Vibration a/k m/s ²	2.8/0.7
Max Air Consumption CFM/(L/S)	15.0/(7.1)
Avg Air Consumption CFM/(L/S)	2.5/(1.2)

Standard Accessory
Chuck Handle
KD-002 (3/8" Drill Chuck w/Handle KG1)

SI-5505 Reversible Drill

- 3/8" capacity geared pistol grip drill with solid composite body
- Supplied with keyless chuck
- Solid composite body absorbs the vibration remarkably and also protects your hand in a cold environment
- Keyless chuck enable the quick change of drill bits

SI-5505

Free Speed r.p.m.	1,900
Chuck Size mm/(in.)	10/(3/8)
Drilling Cap mm/(in.)	10/(3/8)
Out Put Watt	158
Max Torque Nm/(ft-lb)	F 2.05/(1.51) R 1.81/(1.33)
Weight kg/(lb)	0.75/(1.65)
Noise Level dBA/(power)	80/(91)
Vibration a/k m/s ²	2.5/0.7
Max Air Consumption CFM/(L/S)	15.6/(7.4)
Avg Air Consumption CFM/(L/S)	2.6/(1.2)

Standard Accessory
(Yukiwa)
LX10

SI-5800 Spot Mill

- Specially designed to remove spot welds on body panels of motorcars. Work guide makes easy operation
- Easy to adjust depth of cut
- Special designed tool for spot welding separation
- With ø8mm Mill
- With sleeve for ø6.5mm Mill

SI-5800

Free Speed r.p.m.	1,600
Chuck Size mm/(in.)	8/(5/8)
Endmill Size	ø8
Milling Cap mm/(in.)	8/(5/16)
Out Put Watt	197
Weight kg/(lb)	1.80/(3.96)
Noise Level dBA/(power)	82/(93)
Vibration m/s ²	<2.5
Max Air Consumption CFM/(L/S)	18.0/(8.5)
Avg Air Consumption CFM/(L/S)	3.0/(1.4)

Standard Accessory
271-17

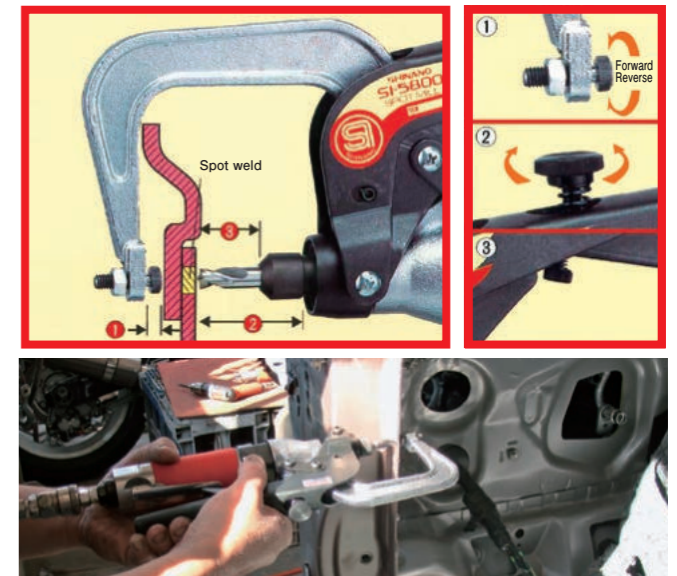

SI-5850 Spot Mill

- Specially designed to remove spot welds on body panel of motorcars
- Work guide makes easy operation
- Easy to adjust depth of cut
- Special designed tool for spot welding separation
- With ø8mm Mill

SI-5850

Free Speed r.p.m.	2,000
Chuck Size mm/(in.)	8/(5/8)
Endmill Size	ø8
Milling Cap mm/(in.)	8/(5/16)
Out Put Watt	390
Weight kg/(lb)	1.39/(3.06)
Noise Level dBA/(power)	83/(94)
Vibration m/s ²	<2.5
Max Air Consumption CFM/(L/S)	7.8/(3.7)
Avg Air Consumption CFM/(L/S)	1.3/(0.6)

Standard Accessory
271-17
210-5-1A

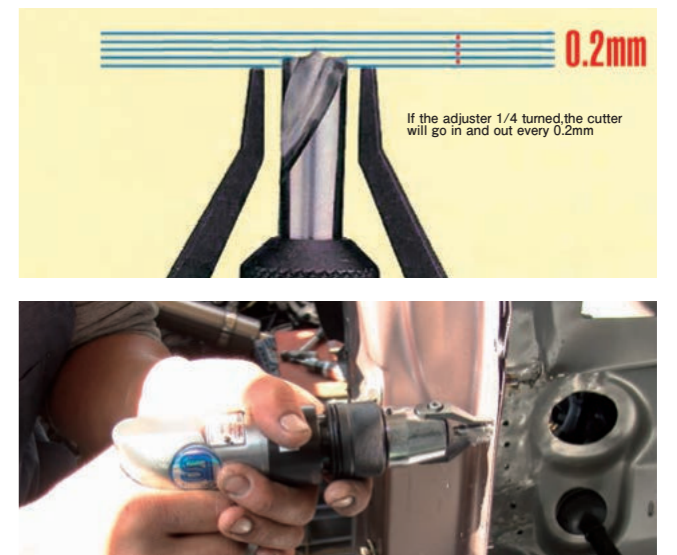

DRILLS / SPOT MILLS ACCESSORIES	KD-004	LX10	LM13W	KD-003A	KD-002	KK	KG1	100	210-5-1A	271-17
	Chuck / Handle	Chuck / Handle	Chuck / Handle	Chuck / Handle	Chuck / Handle	Chuck / Handle	Chuck / Handle	Collet Driver	Dead handle set	ø8mm milling Cutter
	3/8" Drill Chuck	3/8" Keyless Chuck (Yukiwa)	1/2" Keyless Chuck (Yukiwa)	1/2" Drill Chuck	3/8" Drill Chuck	Chuck Handle for KD-004, & KD-003A	Chuck Handle for KD-002			
SI-2015AD	★	☆				★			★	
SI-5100A	★	☆				★				
SI-5200A			☆	★		★			★	
SI-5300A	★	☆				★				
SI-5305A	★	☆				★		☆	☆	
SI-5305-8A			☆	★		★			★	
SI-5501		☆			★			★		
SI-5506		☆			★			★		
SI-5405	☆	★				☆		☆	☆	
SI-5405-6			★	☆		☆		☆	★	
SI-5500		☆			★			★		
SI-5505	☆	★				☆				
SI-5355	★	☆				★				
SI-5800										★
SI-5850									★	★

★ : Standard ☆ : Option



SI-4740

CUTTING TOOLS

- SAWS
- SAWS & FILES
- NIBBLER
- SHEAR
- TRIMMER
- OSCILLATION CUTTER

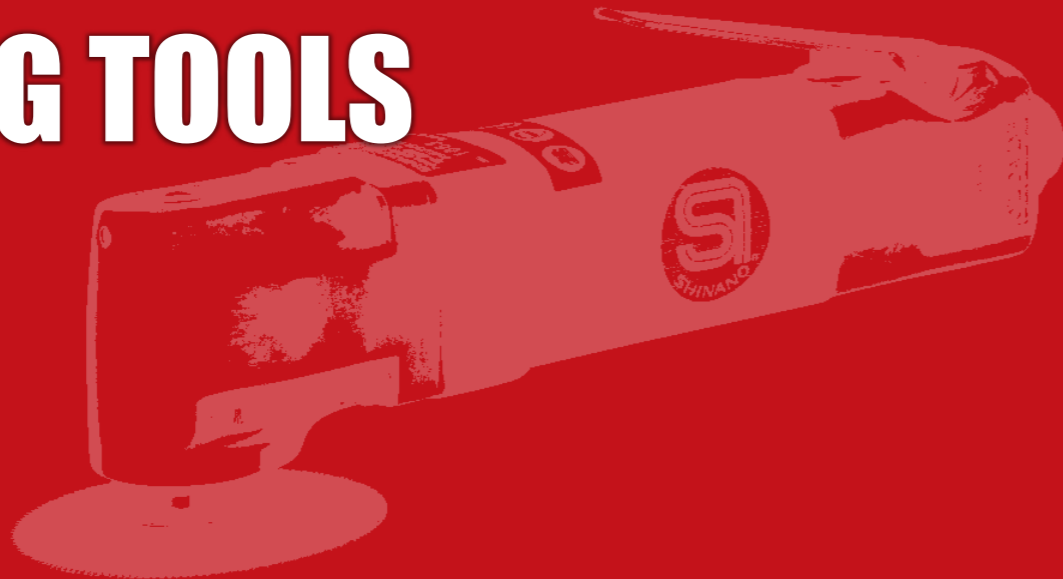

CUTTING TOOLS Saws

SI-4700B

Saw

- This air saw is the most popular tool for cutting body panel of motorcars and one of longest selling models in the automotive repair market
- A popular tool at reasonable price

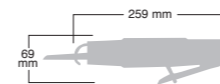

Cutting cap (Steel) mm/(in.)	3/(1/8)
Stroke length mm	10
Free Speed s.p.m. ★	10,000
Weight kg/(lb)	0.58/(1.27)
Noise Level dBA/(power)	82/(93)
Vibration a/k m/s ²	22.6/2.7
Max Air Consumption CFM/(L/S)	7.2/(3.4)
Avg Air Consumption CFM/(L/S)	1.2/(0.6)

★s.p.m. (Stroke Per Minutes)

SI-4730

Saw

- Air saw & file with rotary motor
- SI-4700B & SI-4710 are worked by piston but this model has a rotary air motor and makes working strokes through the gears
- Smooth operation, low vibration and low noise
- Amazing non-stop cutting with extremely low use fatigue

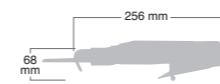

File Shank Opening mm/(in.)	5/(3/16)
Cutting cap (Steel) mm/(in.)	5/(3/16)
Stroke length mm	9
Free Speed s.p.m. ★	6,000
Out Put W	296
Weight kg/(lb)	0.92/(2.03)
Noise Level dBA/(power)	86/(97)
Vibration a/k m/s ²	15.1/1.9
Max Air Consumption CFM/(L/S)	18.0/(8.5)
Avg Air Consumption CFM/(L/S)	3.0/(1.4)

★s.p.m. (Stroke Per Minutes)

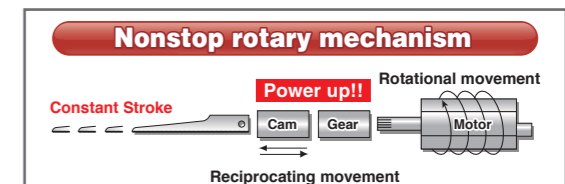

rotary air motor

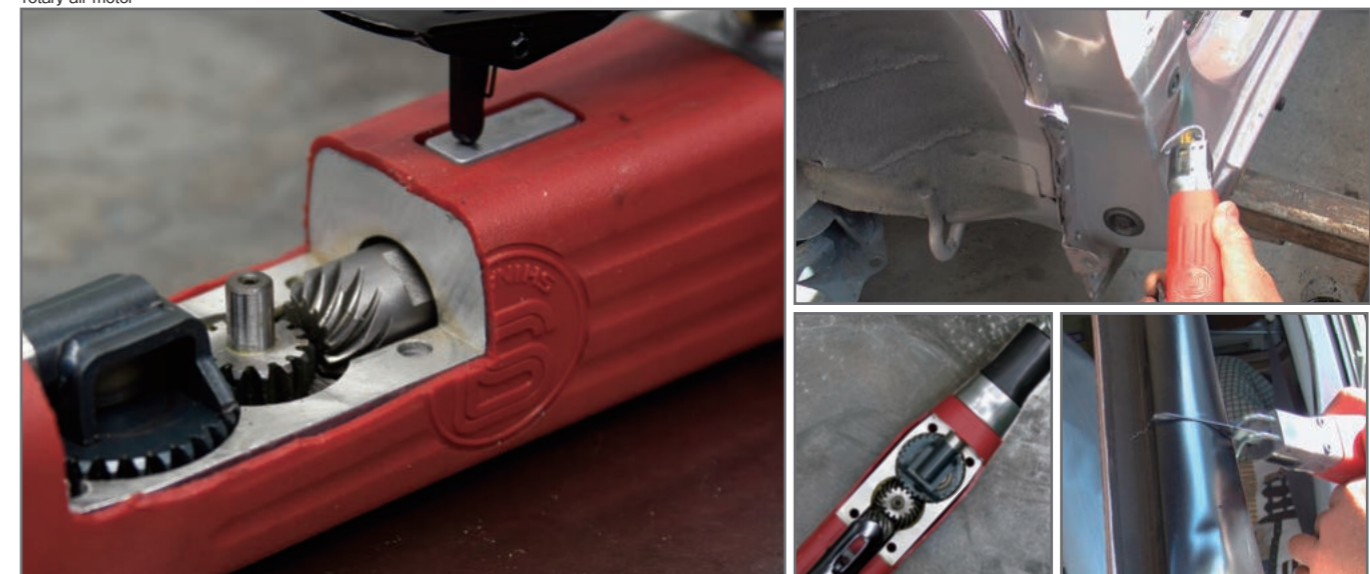

- IMPACT WRENCHES
- DRIVERS
- RATCHET WRENCHES
- SANDERS
- POLISHERS
- GRINDERS
- DRILLS SPOTLIGHTS
- CUTTING TOOLS
- OTHERS
- INDUSTRIAL TOOLS
- ACCESSORIES
- SOUND & VIBRATION
- MAINTENANCE CHECK
- QUALITY

SI-4710

Saw

- Air saw & file
- An improved model over the SI-4700B
- You can use saw blades, as well as 3 different files with this tool
- Low vibration and high power

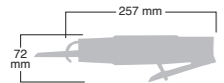

SI-4710 · SI-4710F



SI-4710F



SI-4710F

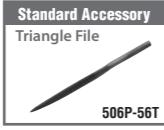

SI-4710F

SI-4710F: Saw Blade and 3files set

SI-4710F

Saw blade and 3files set

Saw & File



File Shank Opening mm/(in.)	5/(3/16)
Cutting cap (Steel) mm/(in.)	3/(1/8)
Stroke length mm	10
Free Speed s.p.m. ★	10,000
Weight kg/(lb)	0.80/(1.76)
Noise Level dBA/(power)	85/(97)
Vibration a/k m/s ²	21.0/1.5
Max Air Consumption CFM/(L/S)	6.0/(2.8)
Avg Air Consumption CFM/(L/S)	1.0/(0.5)

★s.p.m. (Stroke Per Minutes)

SI-4740

Saw

- World's smallest and lightest air saw
- Easy to use in tight place
- This model mechanism is same with the SI-4730. worked by rotary air motor and makes working strokes through the gears
- Only 5mm strokes and other parts are not damaged

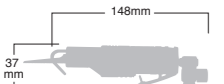

SI-4740 · SI-4740F



SI-4740 · SI-4740F



SI-4740F

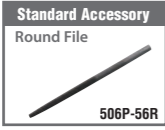

SI-4740F

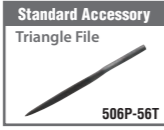

SI-4740F

SI-4740F: Saw Blade and 3files set

SI-4740F

Saw blade and 3files set

Saw & File



File Shank Opening mm/(in.)	5/(3/16)
Cutting cap (Steel) mm/(in.)	4/(5/32)
Stroke length mm	5
Free Speed s.p.m. ★	10,500
Out Put W	135
Weight kg/(lb)	0.52/(1.15)
Noise Level dBA/(power)	83/(94)
Vibration a/k m/s ²	14.5/1.9
Max Air Consumption CFM/(L/S)	10.2/(4.8)
Avg Air Consumption CFM/(L/S)	1.7/(0.8)

★s.p.m. (Stroke Per Minutes)

Nonstop rotary mechanism

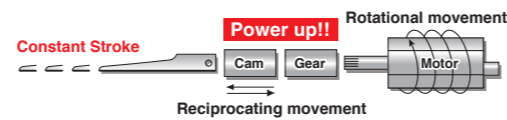

SI-4600

Nibbler



502-42



502-41

Cutting Width mm/(in.)	4.5/(3/16)
Cutting cap mm/(in.)	1.6/(1/16)
Free Speed r.p.m.	2,600
Out Put Watt	316
Weight kg/(lb)	1.00/(2.20)

Noise Level dBA/(power)	88/(99)
Vibration a/k m/s ²	8.6/1.3
Max Air Consumption CFM/(L/S)	19.8/(9.3)
Avg Air Consumption CFM/(L/S)	3.3/(1.6)

SI-4500

Shear

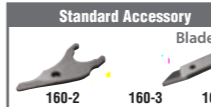

Cutting Width mm/(in.)	5.4/(7/32)
Cutting cap mm/(in.)	1.6/(1/16)
Free Speed r.p.m.	2,000
Out Put Watt	378
Weight kg/(lb)	1.26/(2.79)

Noise Level dBA/(power)	83/(94)
Vibration a/k m/s ²	4.9/0.9
Max Air Consumption CFM/(L/S)	21.0/(9.9)
Avg Air Consumption CFM/(L/S)	3.5/(1.6)

SI-2018A

Trimmer

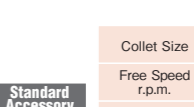

SI-2018A



SI-2018A



SI-2018A-6

SI-2018A-6

6mm Collet model

SI-2018A SI-2018A-6

Collet Size	ø1/4"	ø6mm
Free Speed r.p.m.	26,000	26,000
Output Watt	381	381
Weight kg/(lb)	0.91/(2.01)	0.91/(2.01)
Noise Level dBA/(power)	87/(98)	87/(98)
Vibration a/k m/s ²	<2.5	<2.5
Max Air Consumption CFM/(L/S)	25.2/(11.9)	25.2/(11.9)
Avg Air Consumption CFM/(L/S)	4.2/(2.0)	4.2/(2.0)

SI-4300

Oscillation Cutter

- Oscillation cutting tool specially designed to cut the body panels of motorcars
- Two different cutting blades are supplied with the tool
- Specially designed tool for car repair shop
- The depth of the cut can be adjusted

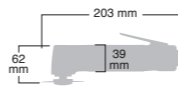

Disc Size mm	ø63
Oscillating Angle	2.8°
Free Speed o.p.m. ★	20,000
Weight kg/(lb)	0.89
Noise Level dBA/(power)	88/(99)
Vibration a/k m/s ²	4.8/0.9
Max Air Consumption CFM/(L/S)	19.2/(9.1)
Avg Air Consumption CFM/(L/S)	3.2/(1.5)

★o.p.m. (Oscillation Per Minutes)















508-45A & 508-44

















SI-4740F



CUTTING TOOLS

CUTTING TOOLS ACCESSORIES	506-49ASI	1025-49ASI	1025-50A	1026-49ASI	506P-56F	506P-56R	506P-56T	502-42	502-41	1026-50
	 Saw blade 32T	 Saw blade 32T	 Saw blade 24T	 Saw blade 32T	 Flat File	 Round File	 Triangle File	 Punch	 Die	 Swivel Regulator Male 1/8" Female 1/4"
 SI-4700B	★	☆	☆							
 SI-4730		★	☆		☆	☆	☆			
 SI-4710	★	☆	☆		☆	☆	☆			
 SI-4710F	★	☆	☆		★	★	★			
 SI-4740				★	☆	☆	☆			★
 SI-4740F				★	★	★	★			★
 SI-4600								★	★	

CUTTING TOOLS ACCESSORIES	160-2	160-3	160-4	508-45A	508-45B	508-44	330-24	330-19	330-25	330-26
	 Center Blade	 Right Blade	 Left Blade	 Cutting Wheel	 Cutting Blade	 Adjuster	 1/4" Collet	 6mm Collet	 1/8" Collet	 3mm Collet
 SI-4500	★	★	★							
 SI-2018A							★	☆	☆	☆
 SI-2018A-6							☆	★	☆	☆
 SI-4300				★	★	★				

★ : Standard ☆ : Option



SI-4600



SI-4500



SI-4160

OTHERS

AIR HAMMER
NEEDLE SCALERS
HYDRO PUNCHER



50

SI-4120A

Air Hammer

- Pistol grip air hammer for 10.2mm diameter chisels (.401" shank)
- Many kinds of the chisels are available as accessories
- High speed piston power of 2,600 times per min
- Powerful piston enable the tool to cope with many kinds of work

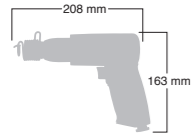

SI-4120AH

Air Hammer Hex Shank



SI-4120A	
SI-4120AH	
Shank Size in./ (mm)	.401/ (10.2)
Stroke length mm	Max 10
Free Blow Speed s.p.m.	2,600
Weight kg/ (lb)	1.60/ (3.52)
Noise Level dBA/ (power)	104/ (116)
Vibration m/s ²	9.0
Max Air Consumption CFM/ (L/S)	18.0/ (8.5)
Avg Air Consumption CFM/ (L/S)	3.0/ (1.4)

AIR HAMMER ACCESSORIES

Special Accessories .401 Shank CHISELS

All products are made in Japan.

No.801		TIE ROD TOOL	No.813		RIVET CUTTER
No.802		TAIL PIPE CUTTER	No.814		BLANK CHISEL
No.803		FORK 21/32" OPENING	No.815		SPOT WELD BREAKER
No.803J		FORK 15/16" OPENING	No.816		SHEET METAL B
No.804		BUSHING REMOVER	No.817		BUSHING DRIVER
No.805		SCRAPER	No.818		FLAT BEND
No.806		BUSHING SPLITTER	No.819		SHEET METAL PUNCH
No.807		SHEET METAL A	No.820		PANEL CLIPER
No.808		MUFFER CUTTER	No.821		SMOOTHING HAMMER
No.809		DOUBLE EDGE PANEL CUTTER	No.822		STRAIGHT PUNCH
No.810		FLAT 7" LONG	No.823		PAINT SCRAPER
No.811		FLAT 9" LONG	No.824		SHOCK ABSORBER CHISEL
No.812		TAPER PUNCH	No.825		MOIL POINT

SI-4160

Needle Scaler

- Pistol type needle scaler is good for holding.
- Ergonomic design with rubber grip giving protects your hand from the cold.
- Excellent performance on uneven or rough surfaces.

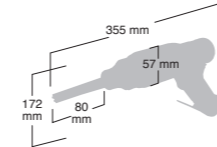

Attachment Included	Attachment Included
φ3 x 180mm 12Needles 820-11	φ3mm Needle Holder 820-9
OPTION	OPTION
φ2 x 180mm 29Needles 820-24	φ2mm Needle Holder 820-23



Stroke length mm	Max 17
Free Blow Speed s.p.m.	3,300
Weight kg/ (lb)	2.19/ (4.83)
Noise Level dBA/ (power)	95/ (108)
Vibration m/s ²	14.1
Max Air Consumption CFM/ (L/S)	8.4/ (4.0)
Avg Air Consumption CFM/ (L/S)	1.4/ (0.7)



SI-4150EX

Needle Scaler

- Straight grip needle scaler for removing rust or old paint. Excellent performance on uneven or rough surfaces.
- Ergonomic grip and composite body design.
- Simple mechanism for easy maintenance and needle replacement.

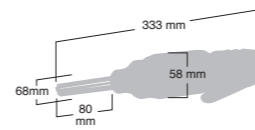

Attachment Included	Attachment Included
φ3 x 180mm 12Needles 820-11	φ3mm Needle Holder 820-9
OPTION	OPTION
φ2 x 180mm 29Needles 820-24	φ2mm Needle Holder 820-23



Stroke length mm	Max 17
Free Blow Speed s.p.m.	3,500
Weight kg/ (lb)	2.06/ (4.53)
Noise Level dBA/ (power)	97/ (107)
Vibration m/s ²	13.0
Max Air Consumption CFM/ (L/S)	7.8/ (3.7)
Avg Air Consumption CFM/ (L/S)	1.3/ (0.6)



SI-4800

Hydro Puncher

- Punching and flanging tool is useful for panel beating work.
- Best tool for welding work of car body.

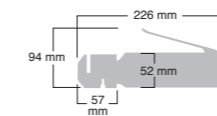

Punching cap mm/ (in.)	ø5 x 1.2mm
Cutting cap mm/ (in.)	1.2/ (3/64)
Weight kg/ (lb)	1.01/ (2.23)
Vibration m/s ²	<2.5
Max Air Consumption CFM/ (L/S)	7.8/ (3.7)
Avg Air Consumption CFM/ (L/S)	1.3/ (0.6)

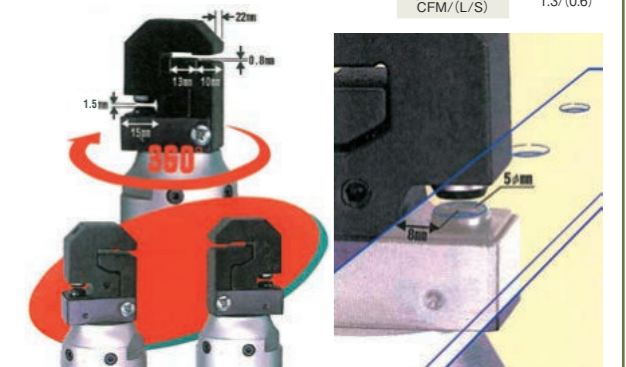

IMPACT WRENCHES
DRIVERS
RATCHET WRENCHES
SANDERS
POLISHERS
GRINDERS
DRILLS SPOTLIGHTS
CUTTING TOOLS
OTHERS
INDUSTRIAL TOOLS
ACCESSORIES
SOUND & VIBRATION
MAINTENANCE CHECK
QUALITY



for Bridge industry



for Shipbuilding industry



for Building industry



for Airplane industry



for Welding industry

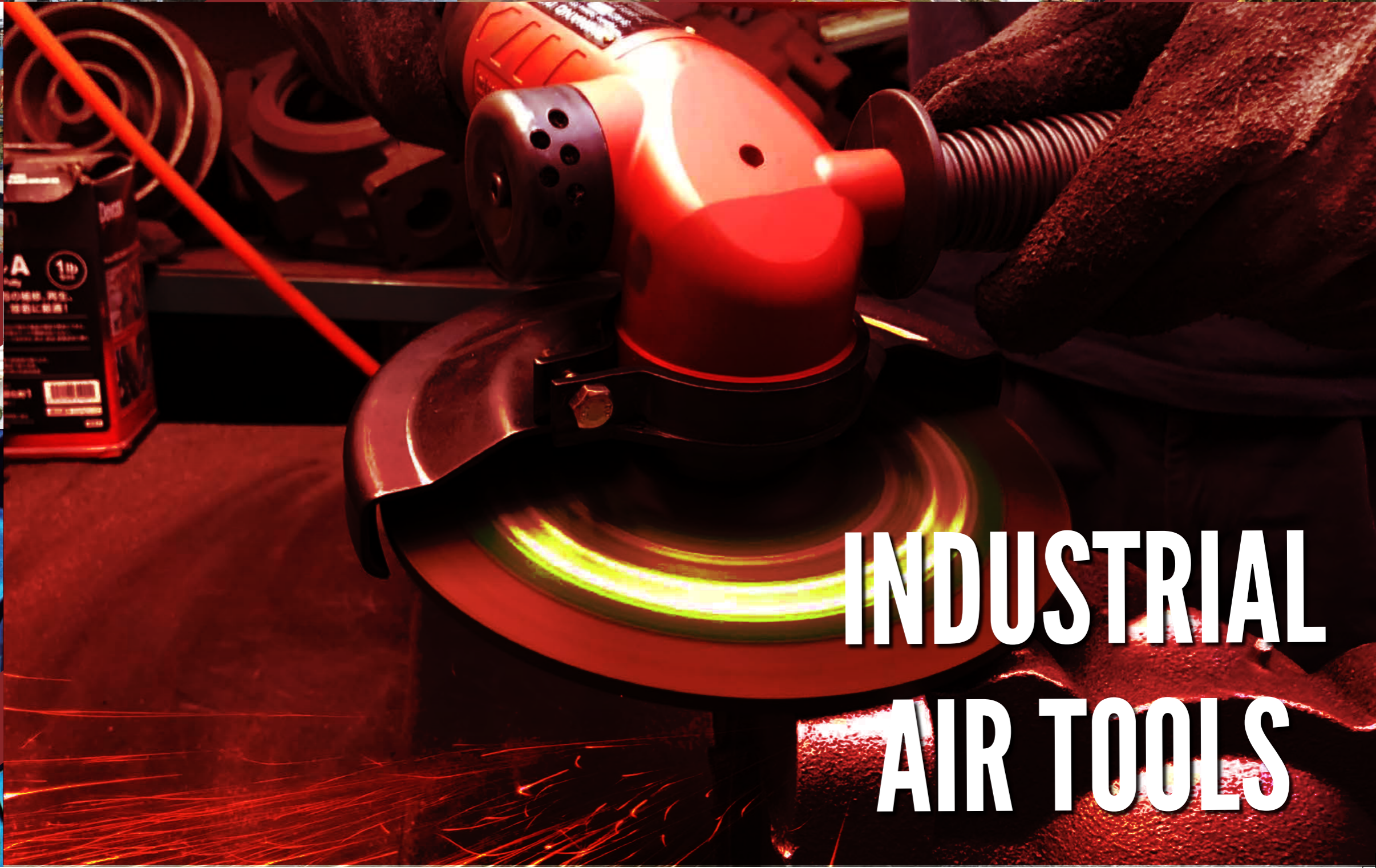

INDUSTRIAL AIR TOOLS

DISC GRINDERS ANGLE GRINDERS.....P57~62

AG2



SI-NO.	Switch type	Description	Spindle size	Disc size
AG2-U2P	Palm grip-safety lever(P)	2"Angle Disc Grinder	Φ9.53-1/4"-28UNF	50X4X9.53
AG2-U2R	Rotary twist switch(R)	2"Angle Disc Grinder	Φ9.53-1/4"-28UNF	50X4X9.53

AG4



SI-NO.	Switch type	Description	Spindle size	Disc size
AG4-E2P	Palm grip-safety lever(P)	4"Angle Disc Grinder	Φ15.8-3/8-24UNF	100X6X15.8
AG4-A2P	Palm grip-safety lever(P)	4"Angle Disc Grinder	Φ15.8-M8-1.25	100X6X15.8
AG4-A2PJ	Palm grip-safety lever(P)	4"Angle Disc Grinder	Φ15-M8-1.25	100X6X15
AG4-E2R	Rotary twist switch(R)	4"Angle Disc Grinder	Φ15.8-3/8-24UNF	100X6X15.8
AG4-A2RJ	Rotary twist switch(R)	4"Angle Disc Grinder	Φ15-M8-1.25	100X6X15
AG4-A2R	Rotary twist switch(R)	4"Angle Disc Grinder	Φ15.8-M8-1.25	100X6X15.8
AG4-A2LJ	Long grip-safety lever(L)	4"Angle Disc Grinder	Φ15-M8-1.25	100X6X15
AG4-A2L	Long grip-safety lever(L)	4"Angle Disc Grinder	Φ15.8-M8-1.25	100X6X15.8
AG4-E2L	Long grip-safety lever(L)	4"Angle Disc Grinder	Φ15.8-3/8-24UNF	100X6X15.8

AG5



SI-NO.	Switch type	Description	Spindle size	Disc size
AG5-E3P	Palm grip-safety lever(P)	5"Angle Disc Grinder	Φ22.2-M14-2	125X6/22.2
AG5-E4P	Palm grip-safety lever(P)	5"Angle Disc Grinder	Φ22.2-5/8-11UNC	125X6/22.2
AG5-A3P	Palm grip-safety lever(P)	5"Angle Disc Grinder	Φ22.2-M8-1.25	125X6/22.2
AG5-A3R	Rotary twist switch(R)	5"Angle Disc Grinder	Φ22.2-M8-1.25	125X6/22.2
AG5-E3L	Long grip-safety lever(L)	5"Angle Disc Grinder	Φ22.2-M14-2	125X6/22.2
AG5-E4L	Long grip-safety lever(L)	5"Angle Disc Grinder	Φ22.2-5/8-11UNC	125X6/22.2
AG5-A3L	Long grip-safety lever(L)	5"Angle Disc Grinder	Φ22.2-M8-1.25	125X6/22.2

AG7



SI-NO.	Switch type	Description	Spindle size	Disc size
AG7-A4R	Rotary twist switch(R)	7"Angle Disc Grinder	Φ22.2-1/2-16UN	180X6X22.2
AG7-A4L	Long grip-safety lever(L)	7"Angle Disc Grinder	Φ22.2-1/2-16UN	180X6X22.2
AG7-E5L	Long grip-safety lever(L)	7"Angle Disc Grinder	Φ22.2-5/8-11UNC	180X6X22.2

STRAIGHT GRINDERS.....P63

SG3



SI-NO.	Switch type	Description	Spindle size	Disc size
SG3-2L	Safety lever(L)	2.5" Straight Disc Grinder	Φ9.53-W3/8-16	65 X 13 X 9.53
SG3-3L	Safety lever(L)	3" Straight Disc Grinder	Φ9.53-W3/8-16	75 X 13 X 9.53
SG3-2R	Rotary twist switch(R)	2.5" Straight Disc Grinder	Φ9.53-W3/8-16	65 X 13 X 9.53
SG3-3R	Rotary twist switch(R)	3" Straight Disc Grinder	Φ9.53-W3/8-16	75 X 13 X 9.53

DIE GRINDERS

COLLET TYPE.....P63

AG2



SI-NO.	Switch type	Description	Spindle size	Collet size
AG2-C2P-6	Palm grip-safety lever(P)	Angle Die Grinder	W3/8-16	6mm
AG2-C2P-Q	Palm grip-safety lever(P)	Angle Die Grinder	W3/8-16	1/4"
AG2-C2R-6	Rotary twist switch(R)	Angle Die Grinder	W3/8-16	6mm
AG2-C2R-Q	Rotary twist switch(R)	Angle Die Grinder	W3/8-16	1/4"

SG3



SI-NO.	Switch type	Description	Spindle size	Collet size
SG3-CL-6	Safety lever(L)	Straight Die Grinder	W3/8-24UNF	6mm
SG3-CL-Q	Safety lever(L)	Straight Die Grinder	W3/8-24UNF	1/4"
SG3-CR-6	Rotary twist switch(R)	Straight Die Grinder	W3/8-24UNF	6mm
SG3-CR-Q	Rotary twist switch(R)	Straight Die Grinder	W3/8-24UNF	1/4"

DUAL ACTION SANDERP64



SI-NO.	Switch type	Description	Paper size
DS6-5L	Short lever	Dual Action Sander	125 φ mm
DS6-5LM	Short lever	Dual Action Sander	125 φ mm

DIE GRINDERS.....P65~66



Angle Model

SI-NO.	Switch type	Description	Collet size
AG20E-6L-6	Safety lever(L)	Angle Die Grinder	6mm
AG20E-6L-Q	Safety lever(L)	Angle Die Grinder	1/4"
AG20E-6R-6	Rotary twist switch(R)	Angle Die Grinder	6mm
AG20E-6R-Q	Rotary twist switch(R)	Angle Die Grinder	1/4"



Light Model

SI-NO.	Switch type	Description	Collet size
SG20E-6L-6	Safety lever(L)	Die Grinder	6mm
SG20E-6L-Q	Safety lever(L)	Die Grinder	1/4"
SG20E-6LL-6	Safety lever(L)	5"EXT Die Grinder	6mm
SG20E-6LL-Q	Safety lever(L)	5"EXT Die Grinder	1/4"
SG20E-6R-6	Rotary twist switch(R)	Die Grinder	6mm
SG20E-6R-Q	Rotary twist switch(R)	Die Grinder	1/4"
SG20E-6RL-6	Rotary twist switch(R)	5"EXT Die Grinder	6mm
SG20E-6RL-Q	Rotary twist switch(R)	5"EXT Die Grinder	1/4"



Standard Model

SI-NO.	Switch type	Description	Collet size
SG40E-6L-6	Safety lever(L)	Die Grinder	6mm
SG40E-6L-Q	Safety lever(L)	Die Grinder	1/4"
SG40E-6LL-6	Safety lever(L)	5"EXT Die Grinder	6mm
SG40E-6LL-Q	Safety lever(L)	5"EXT Die Grinder	1/4"



Power Model

SI-NO.	Switch type	Description	Collet size
SG60E-6L-6	Safety lever(L)	Die Grinder	6mm
SG60E-6L-Q	Safety lever(L)	Die Grinder	1/4"
SG60E-6LL-6	Safety lever(L)	5"EXT Die Grinder	6mm
SG60E-6LL-Q	Safety lever(L)	5"EXT Die Grinder	1/4"

EDGE CUTTERS.....P67~68



High Power Model

SI-NO.	Switch type	Description	Carbide tip type
4010	Rotary twist switch	Edge Cutter	R3 or C3
4010L	Safety lever(L)	Edge Cutter	R3 or C3



Light Model

SI-NO.	Switch type	Description	Carbide tip type
4011	Rotary twist switch	Edge Cutter	R3 or C3
4011L	Safety lever(L)	Edge Cutter	R3 or C3

SHINANO INC.
concepts for the
Industrial range
products are ;

- Productivity
- Accessibility
- Ergonomics
- Durability
- Safety

Target market



Air craft

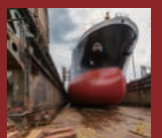

Shipyard

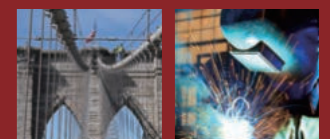

Bridge



Welding



construction

The Industrial range products
have improved 150% on the
accuracy compare with our
automotive range products.

Adjustable Silencer

The 4", 5" & 7" Industrial Angle Grinders feature front mounted 360 degree adjustable silencers. This enables directional control of exhaust air.

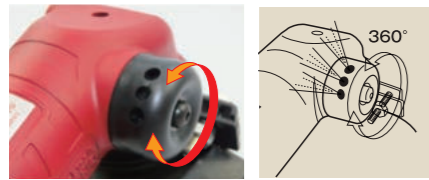

Governed Motor

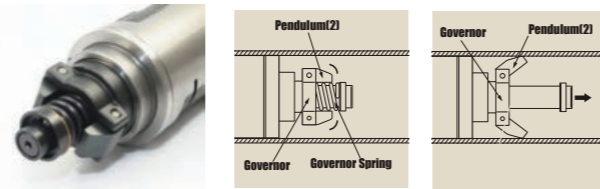

Speed governed motor delivers both higher torque levels and optimal disc RPM for optimum grinding performance.

Spindle Lock



The 2", 4", 5" & 7" Industrial Angle Grinders feature a Spindle lock button for quick and easy grinding disc replacement.

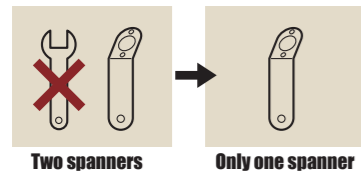

High Precision Bearings & Gears

The Shinano Industrial range has been designed with new high tolerance bearings offering low noise and vibration levels and superior performance at high speeds. Precisely ground transmission gears are made from high grade nickel-chromium molybdenum steel with a specialised hardening process. These high quality specifications allow for a more compact design while maintaining heavy duty performance.



Low Profile Gearbox

Low Profile gearbox greatly increases the operators view of the work area.

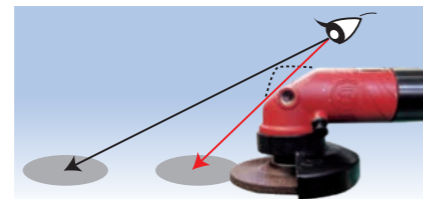

SPINDLE TYPE & SIZE

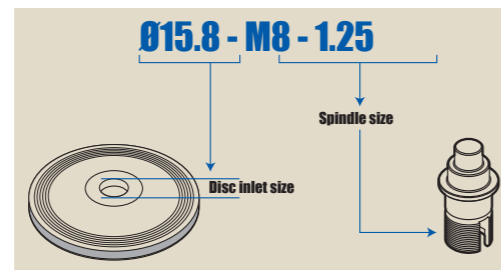

Ergonomic Handle

It is good feeling for operating with soft grip.

Switch Type



Palm grip-safety lever(P)

The safety lever protects from inadvertent starting. When the lever is released, the lever will be locked automatically.



Rotary twist switch(R)

Twist Switch is suitable for Continuous operation. No switch stress to operators.



Long grip-safety lever(L)

The same safety lever system of palm grip. The distance between Wheel and handle is longer than Palm Grip type. It is more safety.

Products No.



Spindle Type

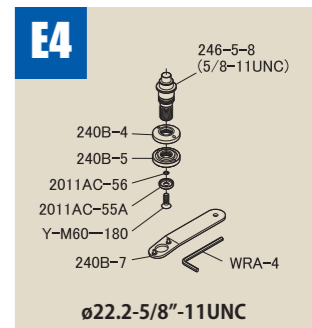
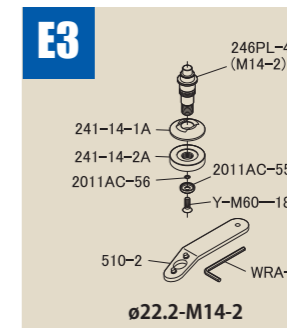
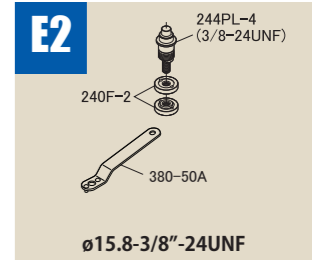
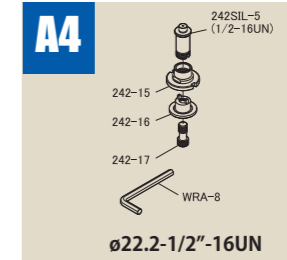
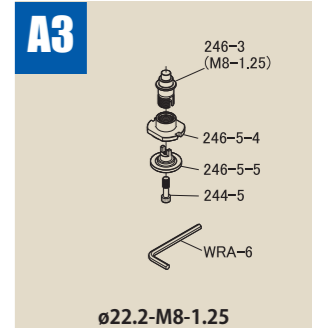
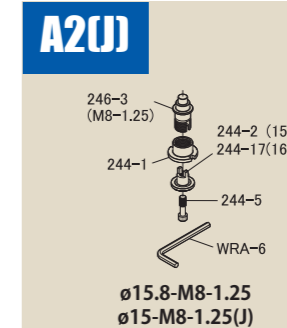
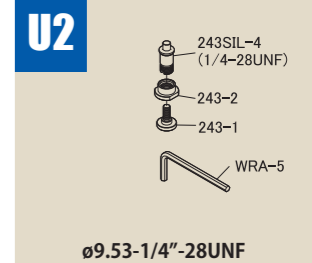
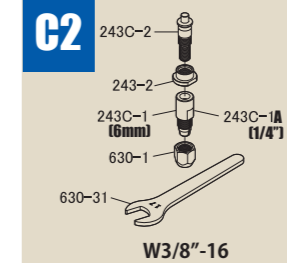

2" (50mm) ANGLE DISC GRINDER

SPINDLE TYPE

U2 Ø 9.53 - 1/4" - 28UNF

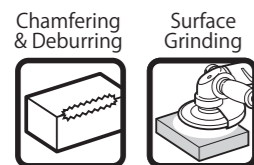

SI-AG2-U2P



Palm grip-safety lever

SI-AG2-U2R



Rotary twist switch

Option Attachment
Parts No.243-30



Option Disc Pad
Parts No.129-100

Option Attachment
Parts No.243-W50
2" Grinding Disc
Disc Size : 50×4×9.53mm

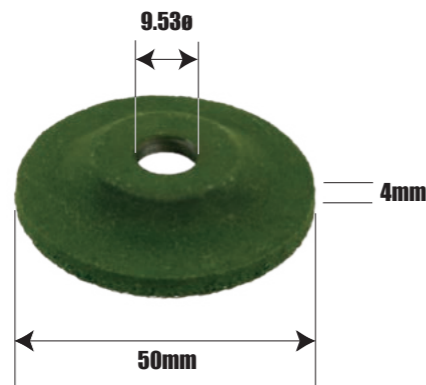

Specifications

SI-No.	Free Speed (rpm)	Motor Watt (w)	Noise Level (db) Press/Power	Vibration(m/s ²)		Air Consumption		Air Inlet Size (inch)	Length (mm)	Width (mm)	Height (mm)	Weight (g)
				a	K	CFM	L/Sec					
SI-AG2-U2P	15,000	240	84/95	7.97	1.28	18.4	8.7	1/4	170	68	65	630
SI-AG2-U2R	15,000	240	84/95	7.97	1.28	18.4	8.7	1/4	170	68	65	640

Noise levels according to ISO 15744:2008,ISO 11203:2009

4" (100mm) ANGLE DISC GRINDER

SPINDLE TYPE

A2 Ø 15.8 - M8 - 1.25

E2 Ø 15.8 - 3/8" - 24UNF

A2(U) Ø 15 - M8 - 1.25

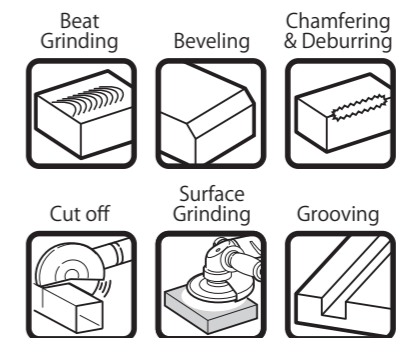

SI-AG4-E2P
SI-AG4-A2P
SI-AG4-A2PJ



Palm grip-safety lever

SI-AG4-A2RJ
SI-AG4-A2R
SI-AG4-E2R



Rotary twist switch

SI-AG4-A2LJ
SI-AG4-A2L
SI-AG4-E2L



Long grip-safety lever



Standard Accessorie

Parts No.240-71E
4" Grinding Disc

Disc Size : 100×6×15.8mm
※This grinding disc is not attached to "J-type".

J-type : SI-AG4-A2PJ, SI-AG4-A2RJ, SI-AG4-A2LJ
Disc Size : 100×6×15mm

Specifications

SI-No.	Free Speed (rpm)	Motor Watt (w)	Noise Level (db) Press/Power	Vibration(m/s ²)		Air Consumption		Air Inlet Size (inch)	Length (mm)	Width (mm)	Height (mm)	Weight (g)
				a	K	CFM	L/Sec					
SI-AG4-E2P	13,500	600	84/95	5.54/13.9	1.8/4.51	20.6	9.7	1/4	214	203	95	1890
SI-AG4-A2P	13,500	600	84/95	5.54/13.9	1.8/4.51	20.6	9.7	1/4	214	203	95	1880
SI-AG4-A2PJ	13,500	600	84/95	5.54/13.9	1.8/4.51	20.6	9.7	1/4	214	203	95	1880
SI-AG4-A2RJ	13,500	600	84/95	5.54/13.9	1.8/4.51	21.3	10	3/8	215	203	95	1750
SI-AG4-A2R	13,500	600	84/95	5.54/13.9	1.8/4.51	21.3	10	3/8	215	203	95	1750
SI-AG4-E2R	13,500	600	84/95	5.54/13.9	1.8/4.51	21.3	10	3/8	215	203	95	1750
SI-AG4-A2LJ	13,500	600	84/95	5.54/13.9	1.8/4.51	19.1	9	3/8	276	203	95	1890
SI-AG4-A2L	13,500	600	84/95	5.54/13.9	1.8/4.51	19.1	9	3/8	276	203	95	1890
SI-AG4-E2L	13,500	600	84/95	5.54/13.9	1.8/4.51	19.1	9	3/8	276	203	95	1900

Noise levels according to ISO 15744:2008,ISO 11203:2009 Vibration level according to ISO 28927-1

5" (125mm) ANGLE DISC GRINDER

SPINDLE TYPE

A3 Ø 22.2 - M8 - 1.25

E3 Ø 22.2 - M14 - 2

E4 Ø 22.2 - 5/8" - 11UNC

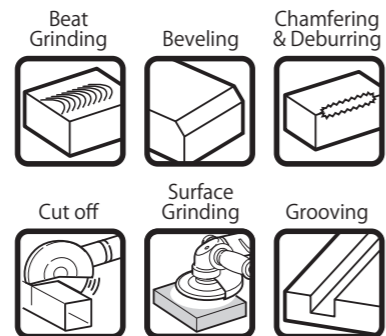

SI-AG5-E3P
SI-AG5-E4P
SI-AG5-A3P



SI-AG5-A3R

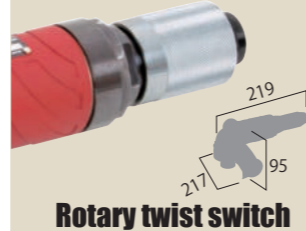

SI-AG5-E3L
SI-AG5-E4L
SI-AG5-A3L

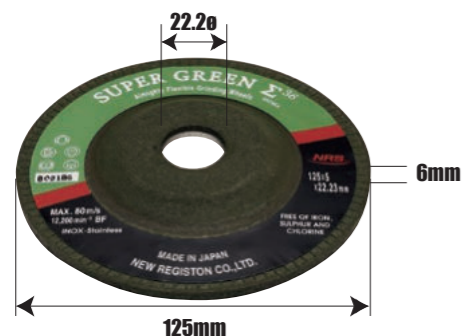

Standard Accessorie
Parts No.241-49E
5" Grinding Disc
Disc Size : 125×6×22.2mm

Specifications

SI-No.	Free Speed (rpm)	Motor Watt (w)	Noise Level (db) Press/Power	Vibration(m/s ²)		Air Consumption		Air Inlet Size (inch)	Length (mm)	Width (mm)	Height (mm)	Weight (g)
				a Body/Grip	K Body/Grip	CFM	(L/sec)					
SI-AG5-E3P	12,000	800	85.5/96.5	7.56/18.9	2.49/6.22	25.5	12	1/4	223	217	95	2050
SI-AG5-E4P	12,000	800	85.5/96.5	7.56/18.9	2.49/6.22	25.5	12	1/4	223	217	95	2050
SI-AG5-A3P	12,000	800	85.5/96.5	7.56/18.9	2.49/6.22	25.5	12	1/4	223	217	95	2020
SI-AG5-A3R	12,000	800	85.5/96.5	7.56/18.9	2.49/6.22	30.1	14.2	3/8	219	217	95	2000
SI-AG5-E3L	12,000	800	85.5/96.5	7.56/18.9	2.49/6.22	31.2	14.7	3/8	285	217	95	2080
SI-AG5-E4L	12,000	800	85.5/96.5	7.56/18.9	2.49/6.22	31.2	14.7	3/8	285	217	95	2080
SI-AG5-A3L	12,000	800	85.5/96.5	7.56/18.9	2.49/6.22	31.2	14.7	3/8	285	217	95	2040

Noise levels according to ISO 15744:2008,ISO 11203:2009 Vibration level according to ISO 28927-1

7" (180mm) ANGLE DISC GRINDER

SPINDLE TYPE

A4 Ø 22.2 - 1/2" - 16UN

E5 Ø 22.2 - 5/8" - 11UNC

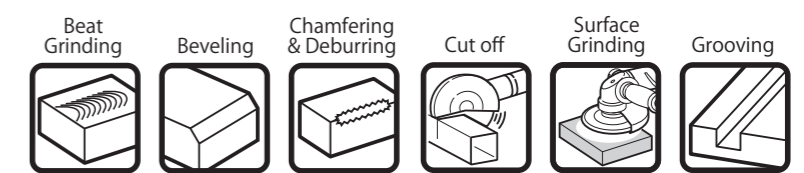

SI-AG7-E5L



SI-AG7-A4R

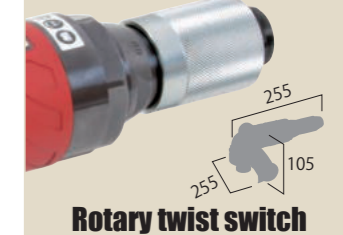

SI-AG7-A4L
SI-AG7-E5L

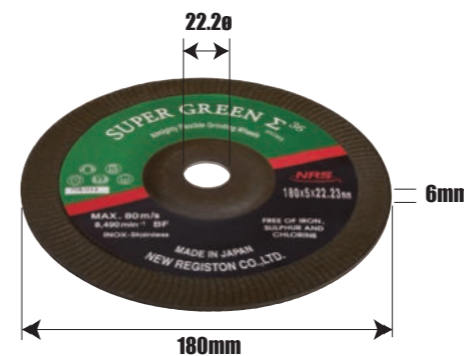

Standard Accessorie
Parts No.280-28E
7" Grinding Disc
Disc Size : 180×6×22.2mm

Specifications

SI-No.	Free Speed (rpm)	Motor Watt (w)	Noise Level (db) Press/Power	Vibration(m/s ²)		Air Consumption		Air Inlet Size (inch)	Length (mm)	Width (mm)	Height (mm)	Weight (g)
				a Body/Grip	K Body/Grip	CFM	(L/sec)					
SI-AG7-A4R	7,600	1,000	84.5/95.5	4.32/6.65	1.39/2.14	19.5	9.2	3/8	255	255	105	2900
SI-AG7-A4L	7,600	1,000	84.5/95.5	4.32/6.65	1.39/2.14	18.1	8.5	3/8	312	255	105	2880
SI-AG7-E5L	7,600	1,000	84.5/95.5	4.32/6.65	1.39/2.14	18.1	8.5	3/8	312	260	135	3300

Noise levels according to ISO 15744:2008,ISO 11203:2009 Vibration level according to ISO 28927-1

STRAIGHT & COLLET TYPE

STRAIGHT TYPE DISC GRINDER

SPINDLE TYPE

Ø 9.53 - W3/8" - 16

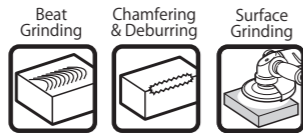

Option Accessorie

Parts No.630-W65

Disc Size :
65 × 13 × 9.53mm
(SI-SG3-2R & SI-SG3-2L)

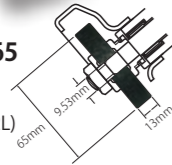

Option Accessorie

Parts No.630-W75

Disc Size :
75 × 13 × 9.53mm
(SI-SG3-3R & SI-SG3-3L)

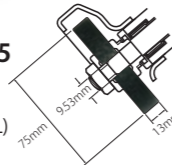

SI-SG3-2L



Palm grip-safety lever

SI-SG3-3L



Palm grip-safety lever

SI-SG3-2R

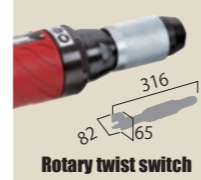

Rotary twist switch

SI-SG3-3R

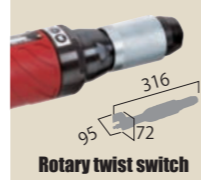

Rotary twist switch

Specifications

SI-No.	Free Speed (rpm)	Motor Watt (w)	Noise Level (db) Press/Power	Vibration(m/s ²)		Air Consumption		Air Inlet Size (inch)	Length (mm)	Width (mm)	Height (mm)	Weight (g)
				a	K	CFM	L/Sec					
SI-SG3-2L	14,600	520	83.5/94.5	2.86	0.78	14.2	6.7	1/4	316	82	95	1660
SI-SG3-3L	12,700	520	83.5/94.5	2.86	0.78	11.0	5.2	1/4	316	95	102	1685
SI-SG3-2R	14,600	520	83.5/94.5	2.86	0.78	16.0	7.5	3/8	316	82	65	1520
SI-SG3-3R	12,700	520	83.5/94.5	2.86	0.78	12.1	5.7	3/8	316	95	72	1545

Noise levels according to ISO 15744:2008,ISO 11203:2009 Vibration level according to ISO 28927-1

COLLET TYPE DIE GRINDER

COLLET TYPE

Ø 6mm or 1/4"

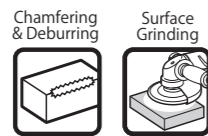

Option Attachment

Parts No.129-101(6mm)

Parts No.129-102(1/4")



Option Disc Pad

Parts No.129-100



SI-AG2-C2P-6 SI-AG2-C2P-Q



Palm grip-safety lever

COLLET TYPE

Ø 6mm or 1/4"

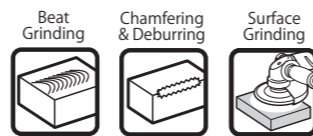

Slimline Shaft

The mid-mounted bearing assembly and extended drive shaft design allows access to confined areas where heavy duty cutting power is needed.



SI-SG3-CL-6 SI-SG3-CL-Q



Palm grip-safety lever

SI-SG3-CR-6 SI-SG3-CR-Q

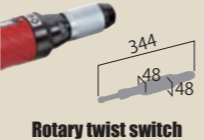

Rotary twist switch

Specifications

SI-No.	Free Speed (rpm)	Motor Watt (w)	Noise Level (db) Press/Power	Vibration(m/s ²)		Air Consumption		Air Inlet Size (inch)	Length (mm)	Width (mm)	Height (mm)	Weight (g)
				a	K	CFM	L/Sec					
SI-AG2-C2P	15,000	240	84/95	7.97	1.28	18.4	8.7	1/4	170	56	90	640
SI-AG2-C2R	15,000	240	84/95	7.97	1.28	18.4	8.7	1/4	157	56	90	650
SI-SG3-CL	14,000	520	83.5/94.5	2.86	0.78	13.1	6.2	1/4	346	48	78	1530
SI-SG3-CR	14,000	520	83.5/94.5	2.86	0.78	13.5	6.3	3/8	344	48	48	1400

Noise levels according to ISO 15744:2008,ISO 11203:2009 Vibration level according to ISO 28927:12

SI-DS6-5L / SI-DS6-5LM

5" Leather Pad

5" Velcro Pad

Features

- Large size motor generate high abrasive power and high free speed 11,200 r.p.m.
- Reduced vibration thanks to wide random shaft.
- Ergonomic grip for easy operation.
- short throttle lever makes you feel that the tool is light weight.
- Safety cover mounted for safety use.



The short throttle lever

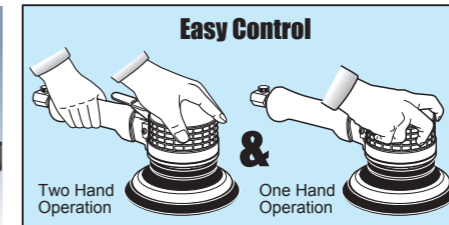

Easy Control

Two Hand Operation

One Hand Operation

The short throttle lever close to center of gravity. Also, easy for one-hand operation.



Wide random shaft reduce the yawing and vibration.



Wide random shaft

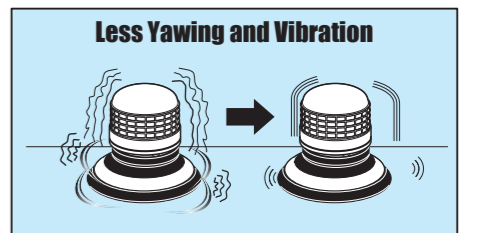

Less Yawing and Vibration

The steel balancer enhance the durability and stable balance.



Durability

Steel Balancer

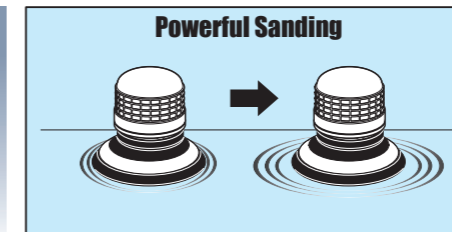

Powerful Sanding

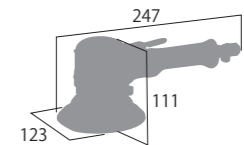

Specifications

SI-No.	Pad/Disc Size (mm/in)	Spindle Size	Orbit Dia (mm)	Free Speed (rpm)	Out Put Watt	Weight (kg)	Noise Level dBA/power	Vibration a/k m/s ²	Air Consumption	
									CFM	L/sec
SI-DS6-5L	125(5")	5/16-24UNF	6	11,200	485	1.54	88.7/(99.7)	7.16/1.36	21.2	10.0
SI-DS6-5LM	125(5")	5/16-24UNF	6	11,200	485	1.54	88.7/(99.7)	7.16/1.36	21.2	10.0

Noise levels according to ISO 15744:2008,ISO 11203:2009 Vibration level according to ISO 28927:12

High Spec Collet



High Spec Collet
Grips at 3 locations.

Standard Collet
Grips at 1 location.

Conventional die grinder collets grip the burr in only one location leaving it susceptible to the effects of "Centre Runout" vibration. The High Spec Collet utilizes its entire length to grip the burr shank, aligning it with the centre of rotation. This reduces vibration which in turn improves control and comfort for the operator and extends the service life of the burr. This is particularly useful when using extended or oversize burrs.

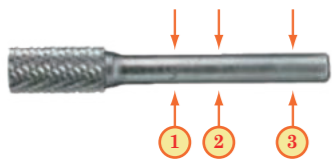

Gears



High Precision Bearings & Gears

The Shinano Industrial range has been designed with new high tolerance bearings offering low noise and vibration levels and superior performance at high speeds. Precisely ground transmission gears are made from high grade nickel-chromium molybdenum steel with a specialised hardening process. These high quality specifications allow for a more compact design while maintaining heavy duty performance.

Safety Lever



The safety lever protects from inadvertent starting. When the lever is released, the lever will be locked automatically.

Rotary Twist Switch(R)



Rotary Twist Switch is suitable for Continuous operation. No switch stress to operators.

Silencer Hose

In addition to significantly reduced noise levels, the 50 cm silencer hose will also ensure that moisture and oil that may be present in exhaust air are directed away from the work area.

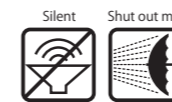

SI-AG20E-6L-6 (6mm collet) SI-AG20E-6L-Q (1/4" collet)



Free Speed..... 20,000 rpm
Motor watt..... 200 w
Weight..... 570 g
Vibration..... a=2.74 m/s²
K=0.77 m/s²

Noise (Press)..... 75.5 db
Noise (Power)..... 86.5 db
Air Consumption..... 14.5 CFM
Air Inlet Size..... 1/4"

SI-AG20E-6R-6 (6mm collet) SI-AG20E-6R-Q (1/4" collet)



Free Speed..... 20,000 rpm
Motor watt..... 160 w
Weight..... 700 g
Vibration..... a=2.74 m/s²
K=0.77 m/s²

Noise (Press)..... 75.5 db
Noise (Power)..... 86.5 db
Air Consumption..... 11.1 CFM
Air Inlet Size..... 1/4"

SI-SG20E-6L-6 (6mm collet) SI-SG20E-6L-Q (1/4" collet)



Free Speed..... 28,000 rpm
Motor watt..... 180 w
Weight..... 380 g
Vibration..... a=2.81 m/s²
K=0.77 m/s²

Noise (Press)..... 75 db
Noise (Power)..... 86 db
Air Consumption..... 14.5 CFM
Air Inlet Size..... 1/4"

SI-SG20E-6R-6 (6mm collet) SI-SG20E-6R-Q (1/4" collet)



Free Speed..... 26,000 rpm
Motor watt..... 150 w
Weight..... 510 g
Vibration..... a=2.81 m/s²
K=0.77 m/s²

Noise (Press)..... 75 db
Noise (Power)..... 86 db
Air Consumption..... 10.6 CFM
Air Inlet Size..... 1/4"

SI-SG40E-6L-6 (6mm collet) SI-SG40E-6L-Q (1/4" collet)



Free Speed..... 25,000 rpm
Motor watt..... 450 w
Weight..... 650 g
Vibration..... a=4.21 m/s²
K=0.55 m/s²

Noise (Press)..... 73.5 db
Noise (Power)..... 84.5 db
Air Consumption..... 26.6 CFM
Air Inlet Size..... 1/4"

SI-SG60E-6L-6 (6mm collet) SI-SG60E-6L-Q (1/4" collet)



Free Speed..... 25,000 rpm
Motor watt..... 650 w
Weight..... 710 g
Vibration..... a=3.93 m/s²
K=0.88 m/s²

Noise (Press)..... 81.5 db
Noise (Power)..... 92.5 db
Air Consumption..... 29.4 CFM
Air Inlet Size..... 1/4"

Rubberised Extension Tube

All LL series extended die grinders feature a rubberized section of the extension tube which provides extra grip and protection against scuffing of the work piece.

SI-SG20E-6RL-6 (6mm collet) SI-SG20E-6RL-Q (1/4" collet)



Free Speed..... 26,000 rpm
Motor watt..... 150 w
Weight..... 810 g
Air Consumption..... 10.6 CFM
Air Inlet Size..... 1/4"

(Body/Grip)
Vibration..... a=2.01/3.2 m/s²
K=0.69/0.81 m/s²
Noise (Press)..... 77.5 db
Noise (Power)..... 88.5 db

SI-SG20E-6LL-6 (6mm collet) SI-SG20E-6LL-Q (1/4" collet)



Free Speed..... 28,000 rpm
Motor watt..... 180 w
Weight..... 680 g
Air Consumption..... 14.5 CFM
Air Inlet Size..... 1/4"

(Body/Grip)
Vibration..... a=2.01/3.2 m/s²
K=0.69/0.81 m/s²
Noise (Press)..... 77.5 db
Noise (Power)..... 88.5 db

SI-SG40E-6LL-6 (6mm collet) SI-SG40E-6LL-Q (1/4" collet)



Free Speed..... 25,000 rpm
Motor watt..... 450 w
Weight..... 1,120 g
Air Consumption..... 26.6 CFM
Air Inlet Size..... 1/4"

(Body/Grip)
Vibration..... a=2.66/3.44 m/s²
K=0.76/0.93 m/s²
Noise (Press)..... 83 db
Noise (Power)..... 94 db

SI-SG60E-6LL-6 (6mm collet) SI-SG60E-6LL-Q (1/4" collet)



Free Speed..... 25,000 rpm
Motor watt..... 650 w
Weight..... 1,190 g
Air Consumption..... 29.4 CFM
Air Inlet Size..... 1/4"

(Body/Grip)
Vibration..... a=2.44/4.28 m/s²
K=0.74/0.92 m/s²
Noise (Press)..... 80.5 db
Noise (Power)..... 91.5 db

Noise levels according to ISO 15744:2008,ISO 11203:2009 Vibration level according to ISO 28927:12

Market segments

For Shipyard

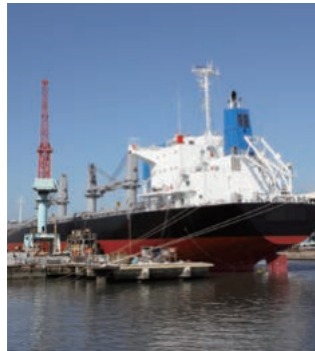

For Construction



For Bridge



IMO PSPC

The Shinano carbide tipped edge cutter is a superior edge finishing solution when compared to conventional edge grinding methods. It can quickly and easily machine consistent beveled or radiused edges that meet and exceed the IMO's PSPC regulations for surface preparation and is suitable for use on aluminium, structural grade steel and most types of stainless steel.

Features

Safety cutting method

The edge cutters are cutting the seat metal with hard tip. It is different method of working between the grinders, reduced sparking and rounded corners are safety since risk of injury.

High quality welding seam

The high quality of the welding seam is a particular advantage. Only one step, that is no need for refreshing and no any working. With our edge cutters can produce clean, burr-free and oxide-free finished edges.

Original Carbide Tip

The router head features three cutting tips for high stock removal. Each tip gives 8 cutting edges offering a long and economical service life.

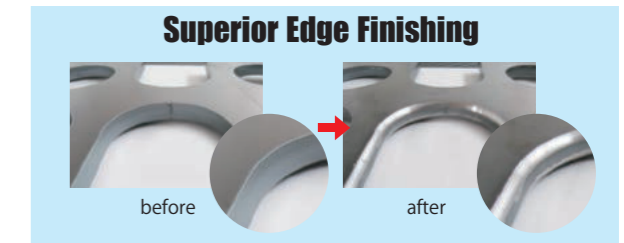

Cutting range of Operation

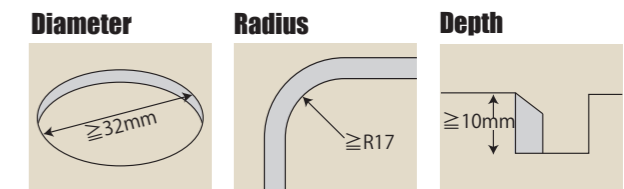

Thickness

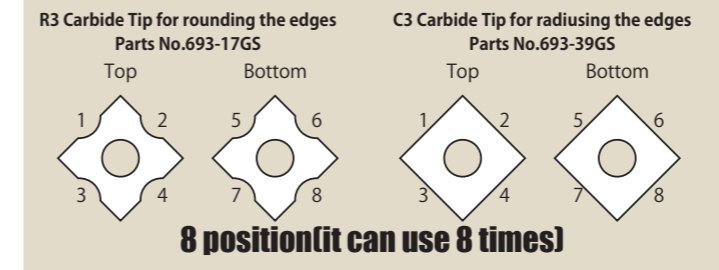
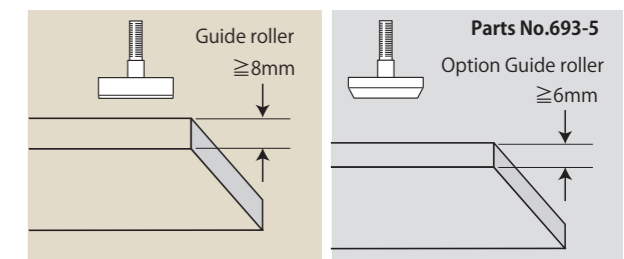

SI-4010L

Free Speed..... 10,000 rpm
Motor watt..... 900 w
Weight..... 3,300 g
Air Consumption.... 34.0 CFM
16.00 L/sec
Air Inlet Size..... 1/4"

High Power Model



Standard Carbide tips
Parts No.693-17GS



Optional Carbide tips
Parts No.693-39GS



SI-4010



Free Speed..... 10,000 rpm
Motor watt..... 900 w
Weight..... 3,360 g
Air Consumption.... 34.0 CFM
16.00 L/sec
Air Inlet Size..... 1/4"

SI-4011L

Free Speed..... 10,000 rpm
Motor watt..... 600 w
Weight..... 2,200 g
Air Consumption.... 29.1 CFM
13.67 L/sec
Air Inlet Size..... 1/4"

Light Model



Standard Carbide tips
Parts No.693-17GS



Optional Carbide tips
Parts No.693-39GS

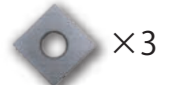

SI-4011



Free Speed..... 10,000 rpm
Motor watt..... 600 w
Weight..... 2,280 g
Air Consumption.... 29.1 CFM
13.67 L/sec
Air Inlet Size..... 1/4"



SHINANO AIR TOOL ACCESSORIES

▶ IMPACT WRENCHES

103-1 Muffler IMPACT WRENCHES	215RA-13 Muffler Filter inside (Quieter than 911P-25) IMPACT WRENCHES	911P-25 Muffler IMPACT WRENCHES	458-58 Housing Cover IMPACT WRENCHES	736-8 Muffler Retainer IMPACT WRENCHES
736DH-10 Retainer IMPACT WRENCHES	911A-15 Muffler Retainer IMPACT WRENCHES	911P-11 Retainer IMPACT WRENCHES	737-26 Housing Cover IMPACT WRENCHES	913-21 Housing Cover IMPACT WRENCHES
967-23 Housing Cover IMPACT WRENCHES				

▶ DRIVERS

181-45 Regulator DRIVERS	181-51 +Bit DRIVERS	181-51A +Bit DRIVERS	458-58 Housing Cover DRIVERS
---	--------------------------------------	---------------------------------------	---

▶ SANDERS

10mm Sanding Belt #40/#60/#80/#100/#120 509-45Z/40 10mm Sanding belt #40 509-45Z/60 10mm Sanding belt #60 509-45Z/80 10mm Sanding belt #80 509-45Z/100 10mm Sanding belt #100 509-45Z/120 10mm Sanding belt #120 BELT SANDERS	20mm Sanding Belt #40/#60/#80/#100/#120 507-58Z/40 20mm Sanding belt #40 507-58Z/60 20mm Sanding belt #60 507-58Z/80 20mm Sanding belt #80 507-58Z/100 20mm Sanding belt #100 507-58Z/120 20mm Sanding belt #120 BELT SANDERS	30mm Sanding Belt #40/#60/#80/#100/#120 505-56Z/40 30mm Sanding belt #40 505-56Z/60 30mm Sanding belt #60 505-56Z/80 30mm Sanding belt #80 505-56Z/100 30mm Sanding belt #100 505-56Z/120 30mm Sanding belt #120 BELT SANDERS	10mm Felt Belt #60/#150/#320 509-130 10mm Felt belt #60 509-131 10mm Felt belt #150 509-132 10mm Felt belt #320 BELT SANDERS	13mm Sanding Belt #60 509LK-106 13mm Sanding belt #60 BELT SANDERS
181-45 Regulator BELT SANDERS	1026-51AS Swivel Regulator Male 1/4" Female 1/4" BELT SANDERS	P-125H 5" Leather Pad 5/16-24UNF SANDERS	M-125H 5" Velcro Pad 5/16-24UNF SANDERS	P-125HD 5" Leather Pad with 6holes 5/16-24UNF SANDERS

▶ SANDERS

M-125HD 5" Velcro Pad with 6holes 5/16-24UNF SANDERS	P-150H 6" Leather Pad 5/16-24UNF SANDERS	M-150H 6" Velcro Pad 5/16-24UNF SANDERS	P-150HD 6 6" Leather Pad with 6holes 5/16-24UNF SANDERS	M-150HD 6 6" Velcro Pad with 6holes 5/16-24UNF SANDERS
M-150HDMH 6" Velcro Pad with Mult holes 5/16-24UNF SANDERS	1041CV-5 6" Velcro Pad Face cover SANDERS	NP-150-120 6" Net Paper#120 SANDERS	NP-150-240 6" Net Paper#240 SANDERS	486-3 6" Leather Pad 5/16-24UNF SANDERS
1140-14M 5" Velcro Pad SANDERS	1140-59M 6" Velcro Pad SANDERS	P-3003 Leather Pad incl. Plate(490-58B)No hole SANDERS	M-3003 Velcro Pad incl. Plate(490-58B)No hole SANDERS	P-3007 Leather Pad incl. Plate(477-44) SANDERS
M-3007 Velcro Pad incl. Plate(477-44) SANDERS	P-3013D Leather Pad incl. Plate(490-58B)with hole SANDERS	M-3013D Velcro Pad incl. Plate(490-58B)with hole SANDERS	475-22 Leather Pad SANDERS	477A-5EL Leather Pad incl 100x180 SANDERS
477A-5EM Velcro Pad incl 100x180 SANDERS	1040-54 ø19mm Dust Hose SANDERS	570-42A ø25mm Dust Hose SANDERS	485-42 Dust Pack SANDERS	

IMPACT WRENCHES
DRIVERS
RATCHET WRENCHES
SANDERS
POLISHERS
GRINDERS
DRILLS
SPOTMILLS
CUTTING TOOLS
OTHERS
INDUSTRIAL TOOLS
ACCESSORIES
SOUND & VIBRATION
MAINTENANCE CHECK
QUALITY

SHINANO AIR TOOL ACCESSORIES

SANDERS

136-45 5" Back Disc  SANDERS	820-52 7" Back Disc  SANDERS	170C-27 3" DiscPad  SANDERS	170C-30 4" DiscPad  SANDERS	129-100 2" Disc Pad  SANDERS
118-3 Triangle Sanding Pad  SANDERS	240-50 Side Handle  SANDERS	1110A-80E ø80mm Velcro Pad(M14 P-2)  SANDERS	M-75H 3" Velcro Pad 5/16-24UNF  SANDERS	M-75HD 3" Velcro Pad with 3holes 5/16-24UNF  SANDERS
MESP-65 ø65mm Sanding Disc  SANDERS	262-21MS ø50mm Velcro Pad M6  SANDERS	114DA-12 ø75mm Velcro Pad M6  SANDERS	SHP-50M-80 ø30mm Sanding Paper  SANDERS	M-20x60/B ø60mm Sponge Buff  SANDERS
M-60 ø60mm Wool Buff  SANDERS	119-101 ø80mm Sponge Buff  SANDERS	119-102 ø80mm Wool Buff  SANDERS	115MB-6S ø30mm SoftPad  SANDERS	115MB-6H ø30mm HardPad  SANDERS
TZ-3000 ø30mm Sanding Paper #3000  SANDERS				

POLISHERS

M-150H 6" Velcro Pad 5/16-24UNF  POLISHERS	114DA-12 ø3" Velcro Pad Thread 6mm  POLISHERS	400E-102 Sponge Buff  POLISHERS	M-150 Wool Buff  POLISHERS	M-75H 3" Velcro Pad 5/16-24UNF  POLISHERS
--	--	--	--	--

POLISHERS

119-101 ø80mm Sponge Buff  POLISHERS	119-102 ø80mm Wool Buff  POLISHERS	NVP75-120 ø75mm Sanding Paper #120  POLISHERS	1145-101 ø165mm Wool Buff  POLISHERS	1145-102 ø165mm Sponge Buff  POLISHERS
1145-5 ø138mm Velcro Pad  POLISHERS	820-52 7" BackDisc  POLISHERS	PW-3100 6" Velcro Pad 5/16-24UNF  POLISHERS		

GRINDERS

330-24 1/4" Collet  GRINDERS	330-19 6mm Collet  GRINDERS	330-25 1/8" Collet  GRINDERS	330-26 3mm Collet  GRINDERS	175-29 3" Cut Disc  GRINDERS
240-6 4" Disc 15mm Hole  GRINDERS	240-71 4" Disc 16mm Hole  GRINDERS	240C-1 Disc Nut for 16mm Hole  GRINDERS	380-44 Disc Nut for 15mm Hole  GRINDERS	241-49E 5" Disc  GRINDERS
280-28 7" Disc  GRINDERS	340-57 30mm Grindstone  GRINDERS	340-2A 3mm Collet  GRINDERS	340-2B 1/8" Collet  GRINDERS	340-55 ø5mm Grindstone(3mm)  GRINDERS
241RW-24 Disc Receiver for SI-2515WE  GRINDERS	241RW-25 Disc Nut for SI-2515WE  GRINDERS			

IMPACT WRENCHES
DRIVERS
RATCHET WRENCHES
SANDERS
POLISHERS
GRINDERS
SPOTMILLS
CUTTING TOOLS
OTHERS
INDUSTRIAL TOOLS
ACCESSORIES
SOUND & VIBRATION
MAINTENANCE CHECK
QUALITY

SHINANO AIR TOOL ACCESSORIES





















▶ DRILLS / SPOT MILLS

KD-004 3/8" Drill Chuck  Chuck / Handle DRILLS / SPOT MILLS	LX10 3/8" Keyless Chuck(Yukiwa)  DRILLS / SPOT MILLS	LM13W 1/2" Keyless Chuck(Yukiwa)  DRILLS / SPOT MILLS	KD-003A 1/2" Drill Chuck  Chuck / Handle DRILLS / SPOT MILLS	KD-002 3/8" Drill Chuck  Chuck / Handle DRILLS / SPOT MILLS
KK Chuck Handle for KD-004, & KD-003A  DRILLS / SPOT MILLS	KG1 Chuck Handle for KD-002  DRILLS / SPOT MILLS	100 Collet Driver  DRILLS / SPOT MILLS	210-5-1A Dead handle set  DRILLS / SPOT MILLS	271-17 ø8mm milling Cutter  DRILLS / SPOT MILLS

▶ CUTTING TOOLS



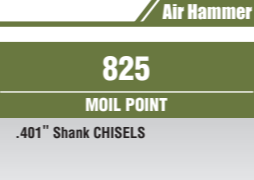
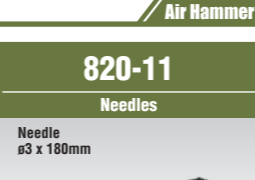
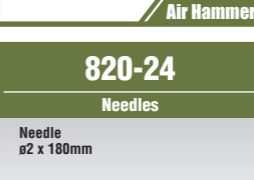









506-49ASI Saw blade 32T  CUTTING TOOLS	1025-49ASI Saw blade 32T  CUTTING TOOLS	1025-50A Saw blade 24T  CUTTING TOOLS	1026-49ASI Saw blade 32T  CUTTING TOOLS	506P-56F Flat File  CUTTING TOOLS
506P-56R Round File  CUTTING TOOLS	506P-56T Triangle File  CUTTING TOOLS	1026-50 Swivel Regulator Male 1/8" Female 1/4"  CUTTING TOOLS	508-45A Cutting Wheel  CUTTING TOOLS	508-45B Cutting Blade  CUTTING TOOLS
508-44 Adjuster  CUTTING TOOLS	502-42 Punch  CUTTING TOOLS	502-41 Die  CUTTING TOOLS	160-2 Center Blade  CUTTING TOOLS	160-3 Right Blade  CUTTING TOOLS
160-4 Left Blade  CUTTING TOOLS	330-24 1/4" Collet  CUTTING TOOLS	330-19 6mm Collet  CUTTING TOOLS	330-25 1/8" Collet  CUTTING TOOLS	330-26 3mm Collet  CUTTING TOOLS

▶ OTHERS

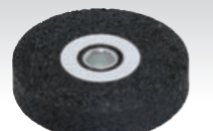
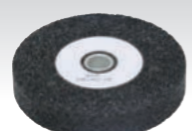
801 TIE ROD TOOL .401" Shank CHISELS  Air Hammer	802 TAIL PIPE CUTTER .401" Shank CHISELS  Air Hammer	803 FORK 21/32" OPENING .401" Shank CHISELS  Air Hammer	803J FORK 15/16" OPENING .401" Shank CHISELS  Air Hammer	804 BUSHING REMOVER .401" Shank CHISELS  Air Hammer
805 SCRAPER .401" Shank CHISELS  Air Hammer	806 BUSHING SPLITTER .401" Shank CHISELS  Air Hammer	807 SHEET METAL A .401" Shank CHISELS  Air Hammer	808 MUFFER CUTTER .401" Shank CHISELS  Air Hammer	809 DOUBLE EDGE PANEL CUTTER .401" Shank CHISELS  Air Hammer
810 FLAT 7" LONG .401" Shank CHISELS  Air Hammer	811 FLAT 9" LONG .401" Shank CHISELS  Air Hammer	812 TAPER PUNCH .401" Shank CHISELS  Air Hammer	813 RIVET CUTTER .401" Shank CHISELS  Air Hammer	814 BLANK CHISEL .401" Shank CHISELS  Air Hammer
815 SPOT WELD BREAKER .401" Shank CHISELS  Air Hammer	816 SHEET METAL B .401" Shank CHISELS  Air Hammer	817 BUSHING DRIVER .401" Shank CHISELS  Air Hammer	818 FLAT BEND .401" Shank CHISELS  Air Hammer	819 SHEET METAL PUNCH .401" Shank CHISELS  Air Hammer
820 PANEL CLIPPER .401" Shank CHISELS  Air Hammer	821 SMOOTHING HAMMER .401" Shank CHISELS  Air Hammer	822 STRAIGHT PUNCH .401" Shank CHISELS  Air Hammer	823 PAINT SCRAPER .401" Shank CHISELS  Air Hammer	824 SHOCK ABSORBER CHISEL .401" Shank CHISELS  Air Hammer
825 MOIL POINT .401" Shank CHISELS  Air Hammer	820-11 Needles Needle ø3 x 180mm 12Needles / Products  Needle Scaler	820-24 Needles Needle ø2 x 180mm 29Needles / Products  Needle Scaler	820-23 Needle Holder ø2mm Needle Holder  Needle Scaler	820-9 Needle Holder ø3mm Needle Holder  Needle Scaler

IMPACT WRENCHES
 DRIVERS
 RATCHET WRENCHES
 SANDERS
 POLISHERS
 GRINDERS
 SPOTMILLS
 CUTTING TOOLS
 OTHERS
 INDUSTRIAL TOOLS
 ACCESSORIES
 SOUND & VIBRATION
 MAINTENANCE CHECK
 QUALITY

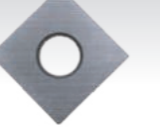
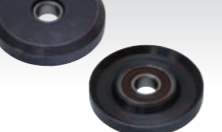
INDUSTRIAL TOOLS

243-30 Disc Pad Attachment  Disc Grinder	129-100 2" Disc Pad  Disc Grinder	243-W50 2" Grinding Disc  Disc Grinder	240-71E 4" Grinding Disc  Disc Grinder	241-49E 5" Grinding Disc  Disc Grinder
280-28E 7" Grinding Disc  Disc Grinder	630-W65 2.5" Grinding Disc  Straight Disc Grinder	630-W75 3" Grinding Disc  Straight Disc Grinder	129-101/129-102 6mm Disc Pad Attachment / 1/4" Disc Pad Attachment  Disc & Die Grinder	114SE-3/114SE-3A 6mm Collet / 1/4" Collet  Die Grinder
892SE-2 / 892SE-2A 6mm Collet / 1/4" Collet  Die Grinder	693-17GS R3 Carbide Tip  Edge Cutter	693-39GS C3 Carbide Tip  Edge Cutter	693-5 Guide Roller ≥ 6mm  Edge Cutter	693-5E Guide Roller ≥ 8mm  Edge Cutter

Exhaust Hose

TYPE-A

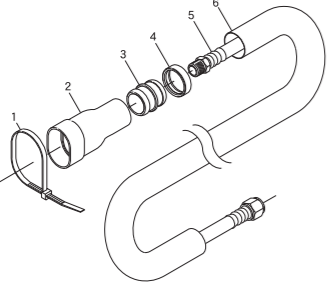

Ref. No.	Parts No.	Description	Q'ty
1	106-10	Harness Band	1
2	106-5	Exhaust Cover A	1
3	106-6	Connector	1
4	106-1	Urethane Band	1
5	106-3	Wipe Hose	1
6	106-2	Exhaust Hose	1
NO.1~6	106-A	Wipe Hose A Assy	1

TYPE-B

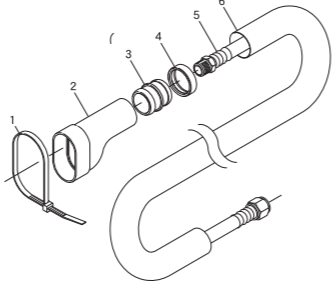

Ref. No.	Parts No.	Description	Q'ty
1	106-10	Harness Band	1
2	106-7	Exhaust Cover B	1
3	106-6	Connector	1
4	106-1	Urethane Band	1
5	106-3	Wipe Hose	1
6	106-2	Exhaust Hose	1
NO.1~6	106-B	Wipe Hose B Assy	1

TYPE-D

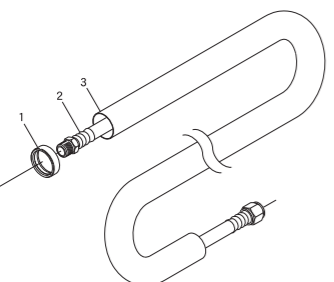

Ref. No.	Parts No.	Description	Q'ty
1	106-1	Urethane Band	1
2	106-3	Wipe Hose	1
3	106-2	Exhaust Hose	1
NO.1~3	106-D	Wipe Hose D Assy	1

TYPE-S

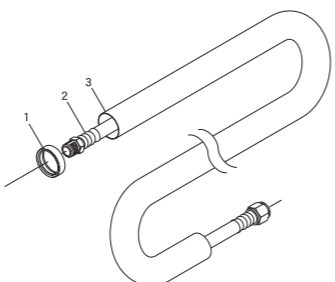

Ref. No.	Parts No.	Description	Q'ty
1	106-8	Urethane Band S	1
2	106-3	Wipe Hose	1
3	106-9	Exhaust Hose S	1
NO.1~3	106-S	Wipe Hose S Assy	1

ANGLE DISC GRINDERS

SI-No.	Noise Level (dBA)		Vibration Level (m/s ²)	
	ISO15744		Body/Grip	
	Pressure	Power	a	K
SI-AG2-U2P	84	95	7.97	1.28
SI-AG2-U2R	84	95	7.97	1.28
SI-AG4-E2P	84	95	5.54/13.9	1.8/4.51
SI-AG4-A2P	84	95	5.54/13.9	1.8/4.51
SI-AG4-A2PJ	84	95	5.54/13.9	1.8/4.51
SI-AG4-A2RJ	84	95	5.54/13.9	1.8/4.51
SI-AG4-A2R	84	95	5.54/13.9	1.8/4.51
SI-AG4-A2LJ	84	95	5.54/13.9	1.8/4.51
SI-AG4-A2L	84	95	5.54/13.9	1.8/4.51
SI-AG4-E2L	84	95	5.54/13.9	1.8/4.51
SI-AG5-E3P	85.5	96.5	7.56/18.9	2.49/6.22
SI-AG5-E4P	85.5	96.5	7.56/18.9	2.49/6.22
SI-AG5-A3P	85.5	96.5	7.56/18.9	2.49/6.22
SI-AG5-A3R	85.5	96.5	7.56/18.9	2.49/6.22
SI-AG5-E3L	85.5	96.5	7.56/18.9	2.49/6.22
SI-AG5-E4L	85.5	96.5	7.56/18.9	2.49/6.22
SI-AG5-A3L	85.5	96.5	7.56/18.9	2.49/6.22
SI-AG7-A4R	84.5	95.5	4.32/6.65	1.39/2.14
SI-AG7-A4L	84.5	95.5	4.32/6.65	1.39/2.14
SI-AG7-E5L	84.5	95.5	4.32/6.65	1.39/2.14

STRAIGHT DISC GRINDERS

SI-No.	Noise Level (dBA)		Vibration Level (m/s ²)	
	ISO15744		Body/Grip	
	Pressure	Power	a	K
SI-SG3-2L	83.5	94.5	2.86	0.78
SI-SG3-3L	83.5	94.5	2.86	0.78
SI-SG3-2R	83.5	94.5	2.86	0.78
SI-SG3-3R	83.5	94.5	2.86	0.78
SI-SG3-CL	83.5	94.5	2.86	0.78
SI-SG3-CR	83.5	94.5	2.86	0.78

DIE GRINDERS

SI-No.	Noise Level (dBA)		Vibration Level (m/s ²)	
	ISO15744		Body/Grip	
	Pressure	Power	a	K
SI-AG2-C2P	84	95	7.97	1.28
SI-AG2-C2R	84	95	7.97	1.28
SI-AG20E-6L	75.5	86.5	2.74	0.77
SI-AG20E-6R	75.5	86.5	2.74	0.77
SI-SG20E-6L	75.5	86	2.81	0.77
SI-SG20E-6LL	77.5	88.5	2.01/3.2	0.77
SI-SG20E-6R	75	86	2.81	0.77
SI-SG20E-6RL	77.5	88.5	2.01/3.2	0.69/0.81
SI-SG40E-6L	73.5	84.5	4.21	0.55
SI-SG40E-6LL	83	94	2.01/3.2	0.69/0.81
SI-SG60E-6L	81.5	92.5	3.93	0.88
SI-SG60E-6LL	80.5	91.5	2.01/3.2	0.69/0.81

SANDER

SI-No.	Noise Level (dBA)		Vibration Level (m/s ²)	
	ISO15744		Body/Grip	
	Pressure	Power	a	K
SI-DS6-5L	88.7	99.7	7.16	1.36
SI-DS6-5LM	88.7	99.7	7.16	1.36



IMPACT WRENCHES
DRIVERS
RATCHET WRENCHES
SANDERS
PUSHERS
GRINDERS
SPOTMILLS
CUTTING TOOLS
OTHERS
INDUSTRIAL TOOLS
ACCESSORIES
SOUND & VIBRATION
MAINTENANCE CHECK
QUALITY

OPERATING ENVIRONMENT

In order to have a tool operate safely and with satisfactory performance, please read the following information thoroughly before considering which SI tool is right for your application.

WORK STATIONS

The tools in this catalogue are intended to be used as a hand-held tool only. It is always recommended that the operator uses the tool in a standing position on a solid floor. These tools can be used in other positions, but before any such use, the operator must ensure they are in a secure position holding the tool firmly and following extra safety precautions that may be required by your workplace.

AIR SUPPLY SYSTEM

To ensure that SI pneumatic tools perform as expected it is necessary to ensure the air supply to the tool is setup correctly. Compressed air must be supplied to the tool at a pressure of 90 PSI (0.63 mpa) when the tool is running with the trigger fully depressed.

Shinano Inc. recommends air regulators, filters, lubricator and water traps be installed in the air supply system. Hose diameter and length can effect the performance of some high capacity pneumatic tools. It is important that the correct hoses and fittings be used. Details of such equipment can be obtained from your pneumatic tool supplier.

It is recommended that the pneumatic tools are connected to an air supply system with a configuration as shown in the diagram below. DO NOT connect a pneumatic tool to the airline system without incorporating an easy to reach and operate air shut off valve. Ensure the air supply system can support the tool(s) that will be connected to it. An air filter, regulator and lubricator units should be installed to the air supply system that powers your pneumatic tools.

DESCRIPTION	
Pressure at the working	0.63MPa (90PSI 6.3bar)
Max Hose Length	10m (30ft)
Lubrication	Daily Lubricating oil

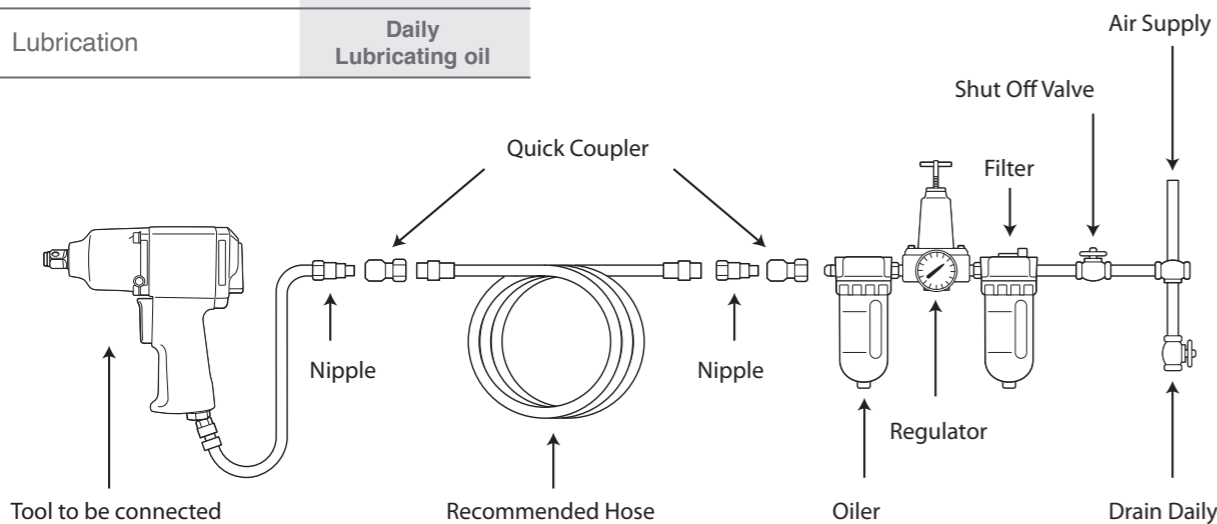

PLANNING AND DEVELOPMENT

Our product development team analyse industry data for the planning of new tools.



DESIGN

Our designs are drawn from over 50 years experience in pneumatic tool design and production, extensive industry research, sound engineering & ergonomic principles and employing modern production techniques.

In our design process, we carefully study the properties and function of each part. We examine the manufacturing parameters of an assembled component, then test for strength and performance.

Shinano Inc. collects data by conducting test experiments in the fields of operator safety, health and workplace productivity. Our designers always aim for perfection in their designs which will in-turn build on the strengths of the SI product range.



PRODUCTION

We believe that precision robotics, combined with the management systems of the human mind produce high quality products at a reasonable price. Our production lines incorporate fully automatic robotics, to accurately, rapidly and efficiently manufacture our products.



CERTIFYING OUR STANDARDS OF QUALITY

Component inspection is carefully carried out at a number of production stages. Inspectors ensure that the production meets the required quality and durability standards. Constant vigilance and daily production inspections ensure the high quality of Shinano Inc. air tools.

