

SI-1052 Impact Driver

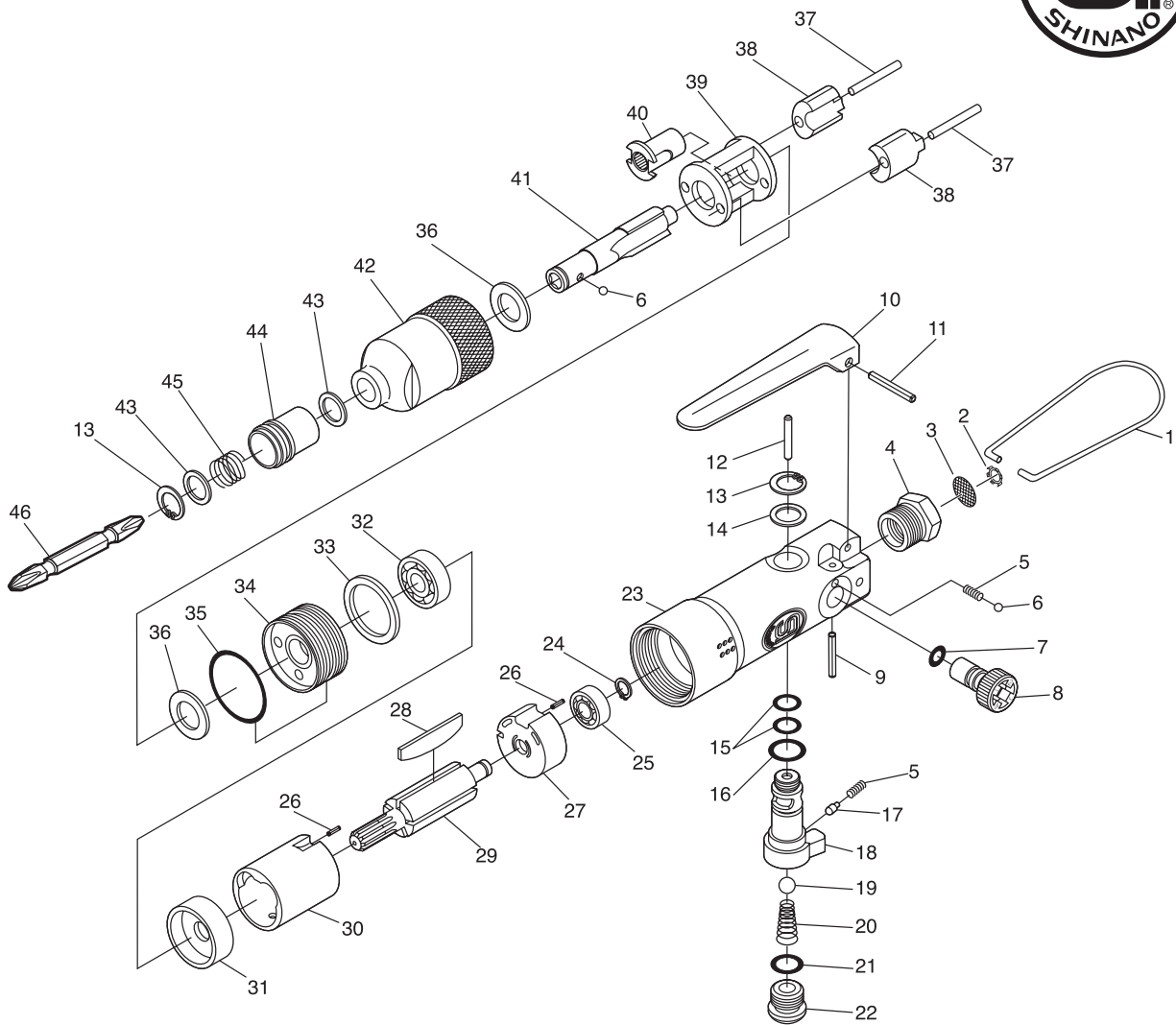

Ref. No.	Parts No.	Description	Q'ty	Ref. No.	Parts No.	Description	Q'ty
1	982-20	Hanger	1	24	JS-6	Retaining Ring	1
2	CRTW-12	Retainer	1	25	606	Ball Bearing	1
3	680-28A	Screen	1	26	15-6	Roll Pin(1.5ø-6mm)	2
4	670-22	Inlet Bushing	1	27	181-19	Rear Plate	1
5	450-45	Spring	2	28	181-23	Rotor Blade	5
6	SB-1/8	Steel Ball	2	29	181-17	Rotor	1
7	P-5	O-Ring	1	30	181-21B	Cylinder	1
8	181B-1A	Air Regulator	1	31	181-24	Front Plate	1
9	25-20	Roll Pin(2.5ø-20mm)	1	32	608-ZZ	Ball Bearing	1
10	350-2	Throttle Lever	1	33	181-27	Spacer	1
11	30-24	Roll Pin(3ø-24mm)	1	34	181-28	Lock Nut incl. Cam Bush(181-30)	1
12	410-2	Valve Pin	1	35	G-25	O-Ring	1
13	GV-10	Retaining Ring	2	36	181-36	Spacer	2
14	181-6A	Washer	1	37	181-33	Hammer Pin	2
15	S-8	O-Ring	2	38	181-32	Hammer Dog	2
16	S-11	O-Ring	1	39	181-34	Hammer Cage	1
17	670-17	Reverse Pin	1	40	181-31	Drive Cam	1
18	181-5A	Reverse Lever	1	41	181-35A	1/4" Hex. Anvil	1
19	181-56	Valve	1	42	181-39A	Hammer Case incl. Bush(181-38)	1
20	140-6	Valve Spring	1	43	181-52	Ret. Washer	2
21	P-9	O-Ring	1	44	181-54	Chuck Sleeve	1
22	800-14	Valve Screw	1	45	181-55	Chuck Sleeve Spring	1
23	181B-2	Motor Housing	1	46	181-51A	+Bit No.2	1