

SI-1062

Impact Driver

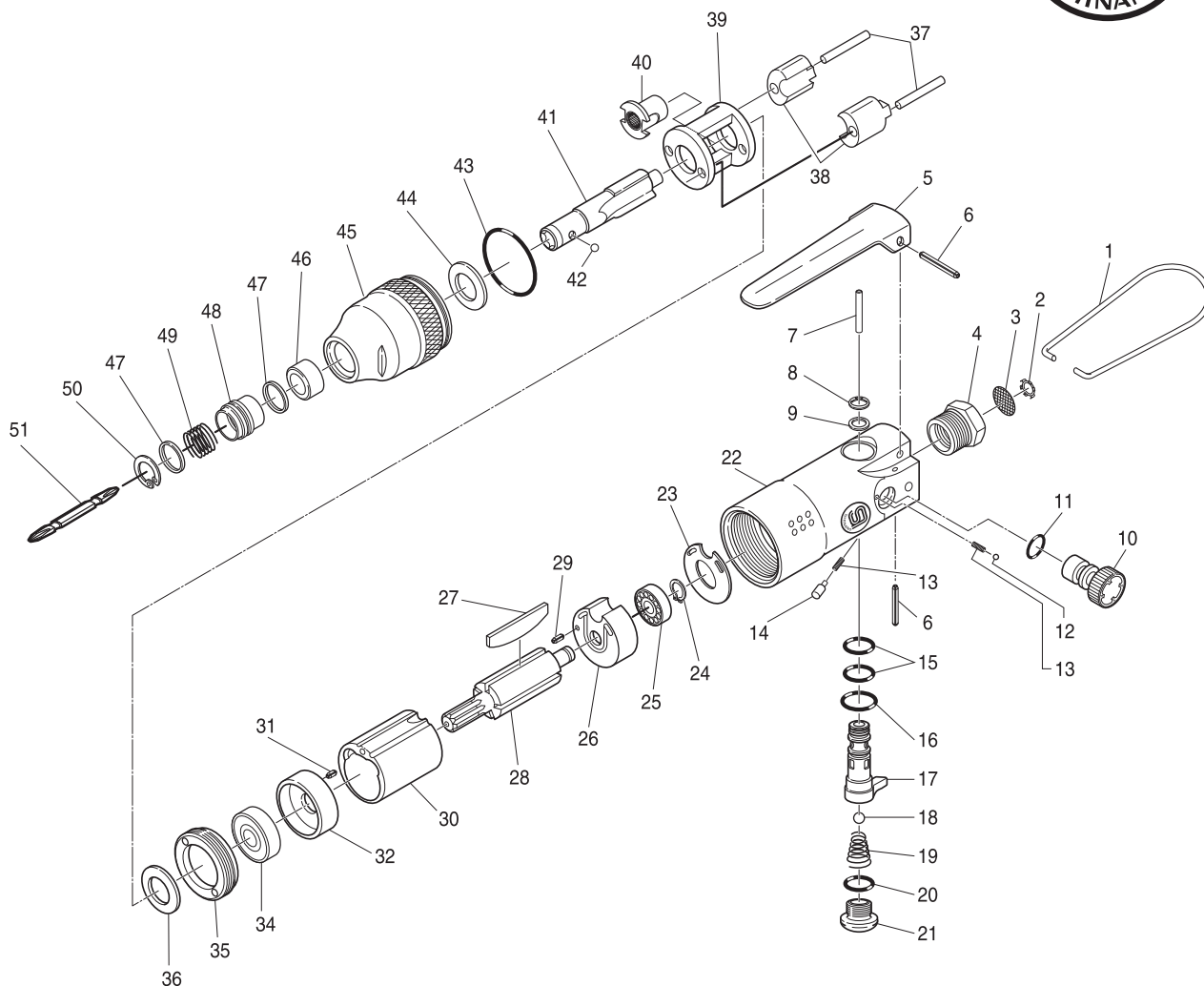

Ref. No.	Parts No.	Description	Q'ty	Ref. No.	Parts No.	Description	Q'ty
1	982-20	Hanger	1	27	190-1	Rotor Blade	5
2	CRTW-12	Retainer	1	28	190-21	Rotor	1
3	680-28A	Screen	1	29A	20-15	Roll Pin(2φ -15mm)	1
4	670-22	Inlet Bushing	1	30	191-7	Cylinder	1
5	350-2	Throttle Lever	1	31	20-8	Roll Pin(2φ -8mm)	1
6	30-24	Roll Pin(3φ -24mm)	2	32	190-19	Front Plate	1
7	410-2	Valve Pin	1	34	608-ZZ	Ball Bearing	1
8	GV-10	Retaining Ring	1	35	190-16	Lock Nut	1
9	181-52	Ret.Washer	1	36	190-14	Spacer	1
10	191A-4	Air Regulator	1	37	190-11	Hammer Pin	2
11	P-8	O-Ring	1	38	190-10	Hammer Dog	2
12	SB-1/8	Steel Ball	1	39	190-13	Hammer Cage	1
13	450-45	Spring	2	40	190-12	Cam	1
14	670-17	Reverse Pin	1	41	190-9	1/4" Hex.Anvil	1
15	S-8	O-Ring	2	42	SB-45	Steel Ball	1
16	S-11.2	O-Ring	1	43	S-34	O-Ring	1
17	191A-1	Reverse Lever	1	44	190-8	Anvil Spacer	1
18	181-56	Valve	1	45	190-6	Hammer Case incl. Anvil Bush(360-20)	1
19	140-6	Valve Spring	1	46	360-20	Anvil Bush	1
20	S-11	O-Ring	1	47	430-52	Retaining Washer	2
21	800-14	Valve Screw	1	48	430-51	Chuck Sleeve	1
22	191A-2	Motor Housing	1	49	430-53	Chuck Sleeve Spring	1
23	191-8	Motor Gasket	1	50	GV-12	Retaining Ring	1
24	JS-6	Retaining Ring	1	51	181-51A	+Bit	1
25	626	Ball Bearing	1				1
26	191-6	Rear Plate	1				