

SI-1356D

Impact Driver

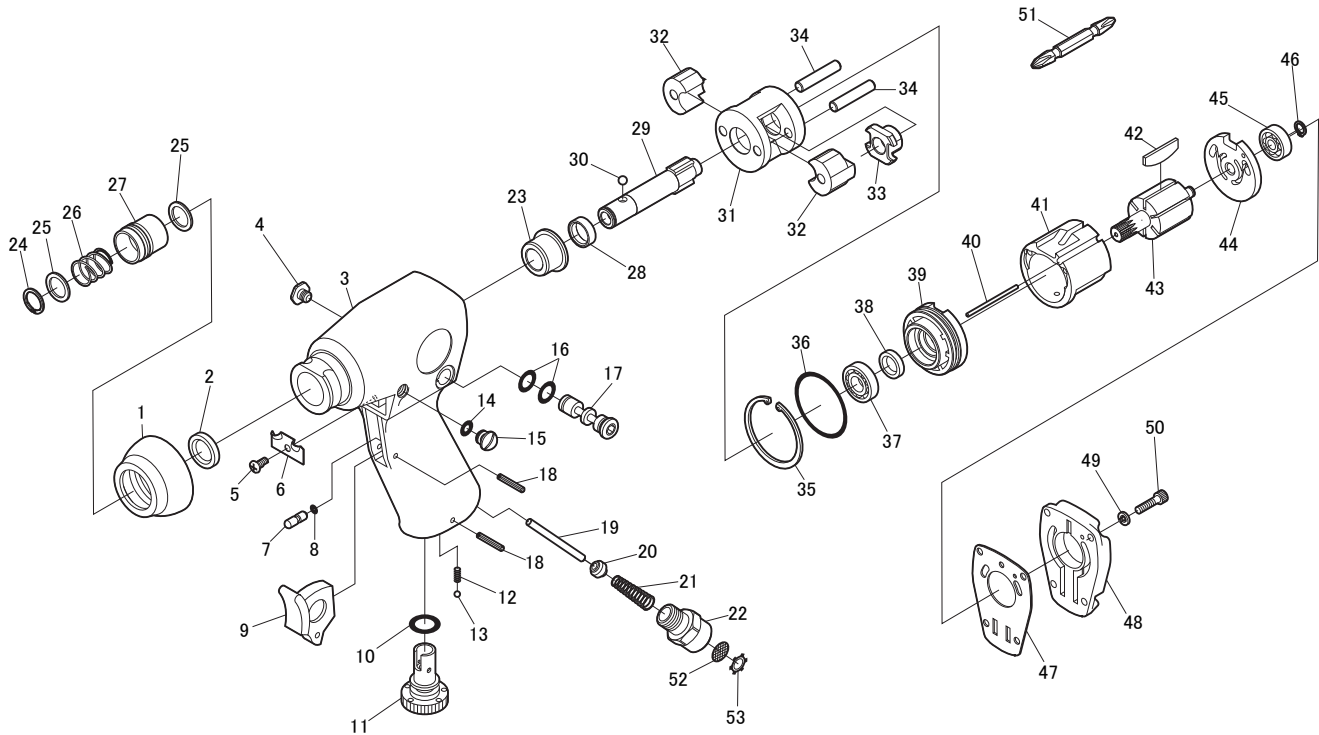

Ref. No.	Parts No.	Description	Q'ty	Ref. No.	Parts No.	Description	Q'ty
1	450-32	Rubber Cap	1	27	430-51	Chuck Sleeve	1
2	450-17	Oil Seal	1	28	450-54	Collar	1
3	445-1	Motor Housing incl. Seal & Bushes (450-17, 445-2, 445-46, 450-20)	1	29	452-4k	1/4" Hex Anvil	1
4	445-26	ReverseValve Screw	1	30	SB-3/16	Steel Ball	1
5	JBM40-80	Screw	1	31	452-1	Hammer Cage	1
6	445-34	Deflector	1	32	450-51	Hammer Dog	2
7	440-18	Push Pin	1	33	452-3	Cam	1
8	440-26	Push Pin O-Ring	1	34	450-52	Hammer Pin	2
9	930-19	Trigger	1	35	JO-40	Retaining Ring	1
10	P-12	O-Ring	1	36	450-35	O-Ring	1
11	930-10	Air Regulator	1	37	EE3	Ball Bearing	1
12	450-45	Regulator Spring	1	38	450-18	Oil Seal	1
13	SB-1/8	Steel Ball	1	39	455-3	Front Plate	1
14	P-5	O-Ring	1	40	445-27	Motor Pin	1
15	450-29	Plug	1	41	450-56	Cylinder	1
16	P-9	O-Ring	2	42	450-37	Rotor Blade	6
17	445-10	ReverseValve	1	43	450-9	Rotor	1
18	30-20	Roll Pin (3ø-20mm)	2	44	445-3	Rear Plate	1
19	930-12	Valve Pin	1	45	626	Ball Bearing	1
20	930B-12B	Valve	1	46	JS-6	Retaining Ring	1
21	440-33	Valve Spring	1	47	445-15	Motor Gasket	1
22	990-26-5	Inlet Bushing	1	48	445-45	Housing Cap	1
23	450-20	Anvil Bushing	1	49	HSW-40	Washer	4
24	GV-12	Retaining Ring	1	50	Z-832-160	Cap Screw	4
25	430-52	Retaining Washer	2	51	181-51A	+ Bit No.2	1
26	430-53	Chuck Sleeve Spring	1	52	680-28A	Screen	1
				53	CRTW-12	Retainer	1