

SI-20065

1/4" Angle Die Grinder Rear Exhaust

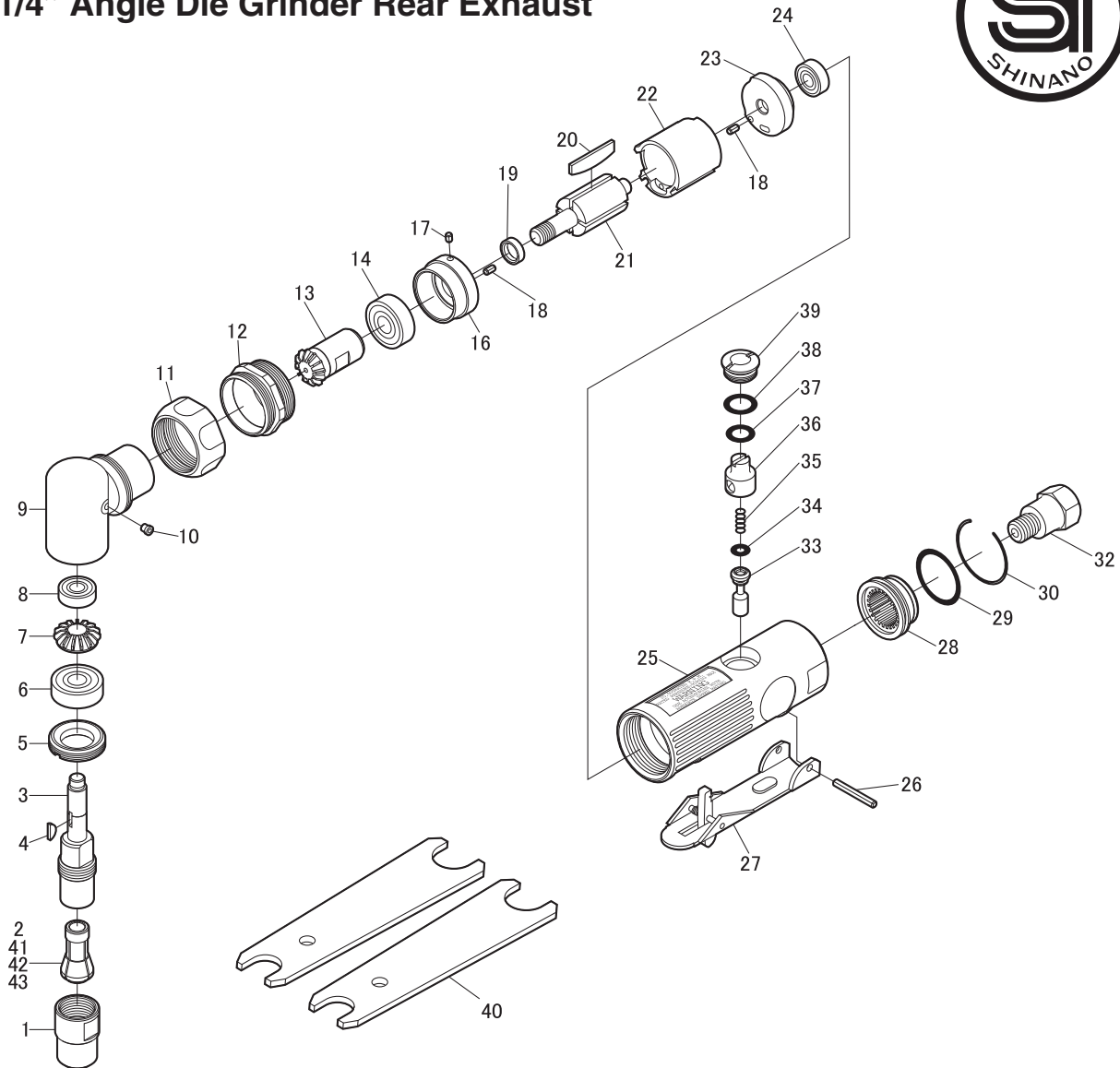

Ref. No.	Parts No.	Description	Q'ty	Ref. No.	Parts No.	Description	Q'ty
1	330-23	Collet Nut	1	23	610-12	Rear Plate	1
2	330-24	1/4" Collet	1	24	696ZZ	Ball Bearing	1
3	115-22	Spindle	1	25	610-1A	Motor Housing incl. Valve Bush (330-4)	1
4	115-36	Key	1	26	30-24	Roll Pin (3ø-24mm)	1
5	115-32	Spindle Nut	1	27	350-2L	Throttle Lever	1
6	608LLU	Ball Bearing	1	28	610-29	Deflector	1
7	115-34B	Bevel Gear	1	29	620-28	O-Ring	1
8	R4ZZ	Ball Bearing	1	30	610-30	Retaining Ring	1
9	115-31	Angle Head	1	32	610-2SC	Inlet Bushing incl. Screen (680-28A) & Retainer (CRTW-12)	1
10	1071C-16	Grease Plug	1				
11	115-27	Angle Head Coupling Nut	1	33	330-5	Valve Stem	1
12	115-26	Motor Clamp Nut	1	34	P-4	O-Ring	1
13	115-33B	Pinion Gear	1	35	350-7	Valve Spring	1
14	608ZZ	Ball Bearing	1	36	330-8A	Air Regulator	1
16	115-19	Front Plate	1	37	P-8	O-Ring	1
17	25-3.5	Roll Pin (2.5ø-3.5mm)	1	38	P-10	O-Ring	1
18	25-5	Roll Pin (2.5ø-5mm)	2	39	330-10	Valve Screw	1
19	330-18	Collar	1	40	330-28	Spanner Wrench (11×17mm)	2
20	330-16	Rotor Blade	4	◆ 41	330-25	1/8" Collet	
21	330-15	Rotor	1	◆ 42	330-26	3mm Collet	
22	330-17	Cylinder	1	◆ 43	330-19	6mm Collet	