

# SI-2322WR-LE

## Wet Sander Safety Lever Type

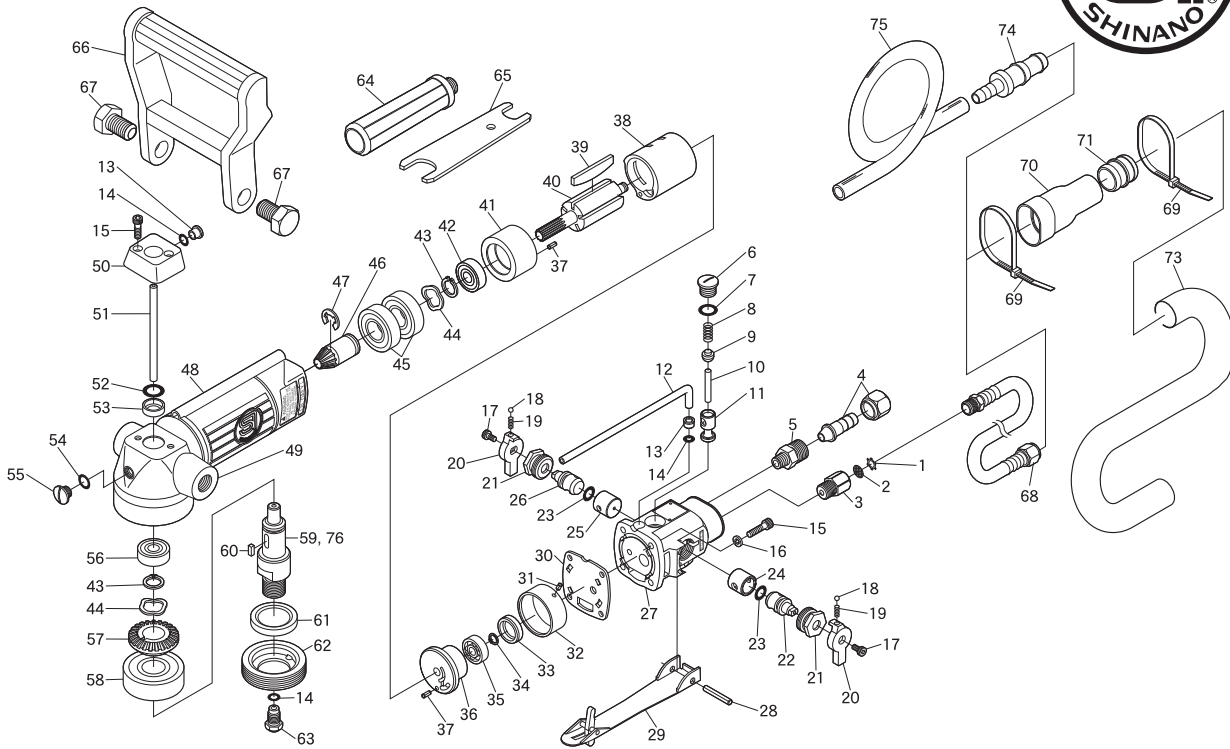

Ref. No.	Parts No.	Description	Q'ty	Ref. No.	Parts No.	Description	Q'ty
1	CRTW-12	Retainer	1	41	1110R-6	Front Plate	1
2	680-28A	Screen	1	42	608ZZ	Ball Bearing	1
3	180-1	Inlet Bushing	1	43	JS-15	Retaining Ring	2
4	1110A-62	Hose Nipple	1	44	WW-150	Wave Washer	2
5	1110A-22	Hose Adaptor	1	45	6002ZZ	Ball Bearing	2
6	800-14	Valve Screw	1	46	1110A-12	Pinion Gear	1
7	P-9	O-Ring	1	47	IE-8	Retaining Ring	1
8	670-49	Valve Spring	1	48	1110RAL-5	Housing Cover	1
9	300-10	Valve	1	49	1110R-1A	Motor Housing	1
10	1110RAL-4	Valve Pin	1	50	1110-3A	Pipe Connector	1
11	1110RAL-3	Valve Bush	1	51	1110-23	Inner Pipe	1
12	1110-9	Outer Pipe	1	52	S-12	O-Ring	1
13	1110-17	Pipe Bush	2	53	G8-14-4	Oil Seal	1
14	P-4	O-Ring	3	54	S-7	O-Ring	1
15	Z-832--160	Cap Screw	6	55	1110A-6	Grease Plug	1
16	HSW-40	Washer	4	56	608LLU	Ball Bearing	1
17	Z-M30---80	Cap Screw	2	57	1110A-13	Bevel Gear	1
18	SB-1/8	Steel Ball	2	58	6302ZZ	Ball Bearing	1
19	450-45	Spring	2	59	1110A-11E	Spindle (M14 P=2)	1
20	1110-4	Lever	2	60	940-46	Key	1
21	1110-21	Valve Nut	2	61	G23-32-7	Oil Seal	1
22	1110A-18	Air Valve	1	62	1110-15	Spindle Cap	1
23	S-8	O-Ring	2	63	1110A-16	Nozzle	1
24	1110A-20B	Air Valve Bush	1	64	240-50	Dead Handle	1
25	1110A-20A	Water Valve Bush	1	65	350-28	Spanner Wrench (14x19mm)	1
26	1110A-19	Water Valve	1	66	1110R-4	Handle	1
27	1110RAL-1A	Valve Housing	1	67	1110R-5	Bolt	2
28	40-25	Roll Pin (4ø-25mm)	1	68	106-3	Wipe Hose	1
29	1110RAL-2	Safety Lever	1	69	106-10	Harness Band	2
30	1110R-3	Gasket	1	70	106-5	Exhaust Cover A	1
31	25-4	Roll Pin (2.5ø-4mm)	1	71	106-6	Connector	1
32	1110A-5	Rear Case	1	73	106-2	Exhaust Hose	1
33	680-34	Bearing Cap	1	74	1110A-61	Water Hose Joint	1
34	JS-6	Retaining Ring	1	75	1110A-64	Water Hose	1
35	626	Ball Bearing	1	★ 76	1110-11	Spindle (M16 P=2)	1
36	1110-26A	Rear Plate	1	◆ 77	1110A-80	80mm Velcro Pad (M16 P=2) Not Shown	1
37	25-5	Roll Pin (2.5ø-5mm)	2	◆ 78	1110A-80E	80mm Velcro Pad (M14 P=2) Not Shown	1
38	1110-24A	Cylinder	1				
39	1110R-8	Rotor Blade	5				
40	1110R-7	Rotor	1				