

# SI-2405

## 6" Vertical Sander/Polisher

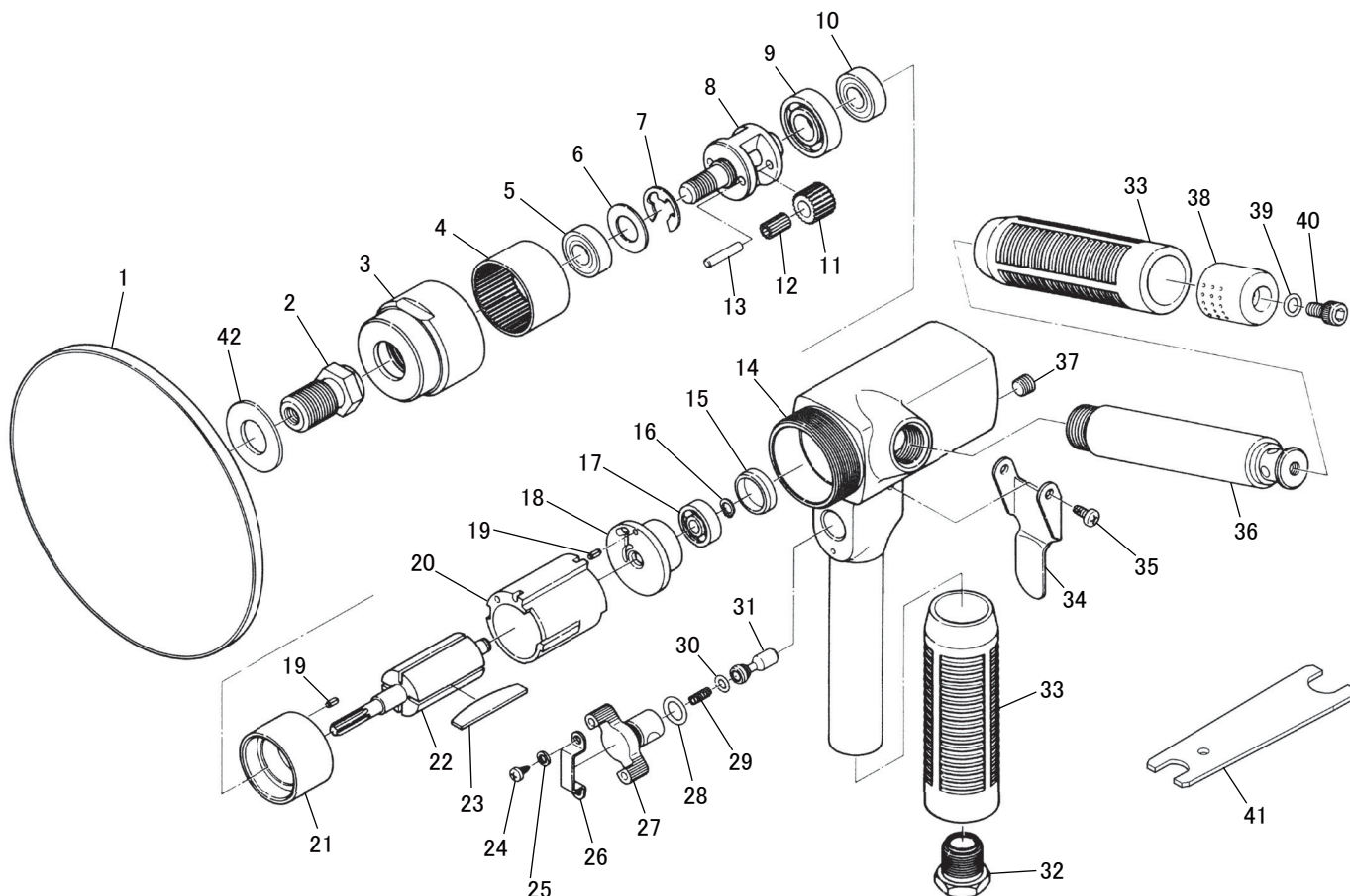

※Please put 242-24 between M-150H and 266-1 when using M-150H Velcro pad.



Ref. No.	Parts No.	Description	Q'ty	Ref. No.	Parts No.	Description	Q'ty
1	M-150H	6" Velcro Pad	1	22	680-5	Rotor	1
2	266-1	Spindle Attachment	1	23	350-16	Rotor Blade	4
3	680-8	Clamp Nut	1	24	JBM35-50	Screw	2
4	680-9	Internal Gear	1	25	HSW-35	Washer	2
5	EE3ZZ	Ball Bearing	1	26	480-16	Regulator Retainer	1
6	680-22	Fiber Washer	1	27	266-28	Regulator	1
7	IE-10	Retaining Ring	1	28	P-8	O-ring	1
8	680-3	Planet Cage	1	29	350-7	Valve Spring	1
9	6001	Ball Bearing	1	30	P-4	O-ring	1
10	608ZZ	Ball Bearing	1	31	330-5	Valve Stem	1
11	266-5	Planet Gear	2	32	650-17	Inlet Bushing	1
12	1500-11-8	Needle Roller	22	33	266-35	Grip Rubber	2
13	680-17	Planet Pin	2	34	266-33	Throttle Lever	1
14	266-45	Motor Housing incl. Valve Bush (330-4)	1	35	JBM40-80	Screw	2
15	680-34	Bearing Cap	1	36	266-37	Dead Handle	1
16	JS-6	Retaining Ring	1	37	PTN-1/16	Plug	1
17	626	Ball Bearing	1	38	266-39	Deflector	1
18	680-2	Rear Plate	1	39	P-6	O-ring	1
19	25-5	Roll Pin (2.5-5mm)	2	40	Z-M60-100	Cap Screw	1
20	266-10	Cylinder	1	41	350-28	Spanner Wrench	1
21	680-4	Front Plate	1	42	242-24	Bearing Cover	1