

SI-4740

Mini Air Saw

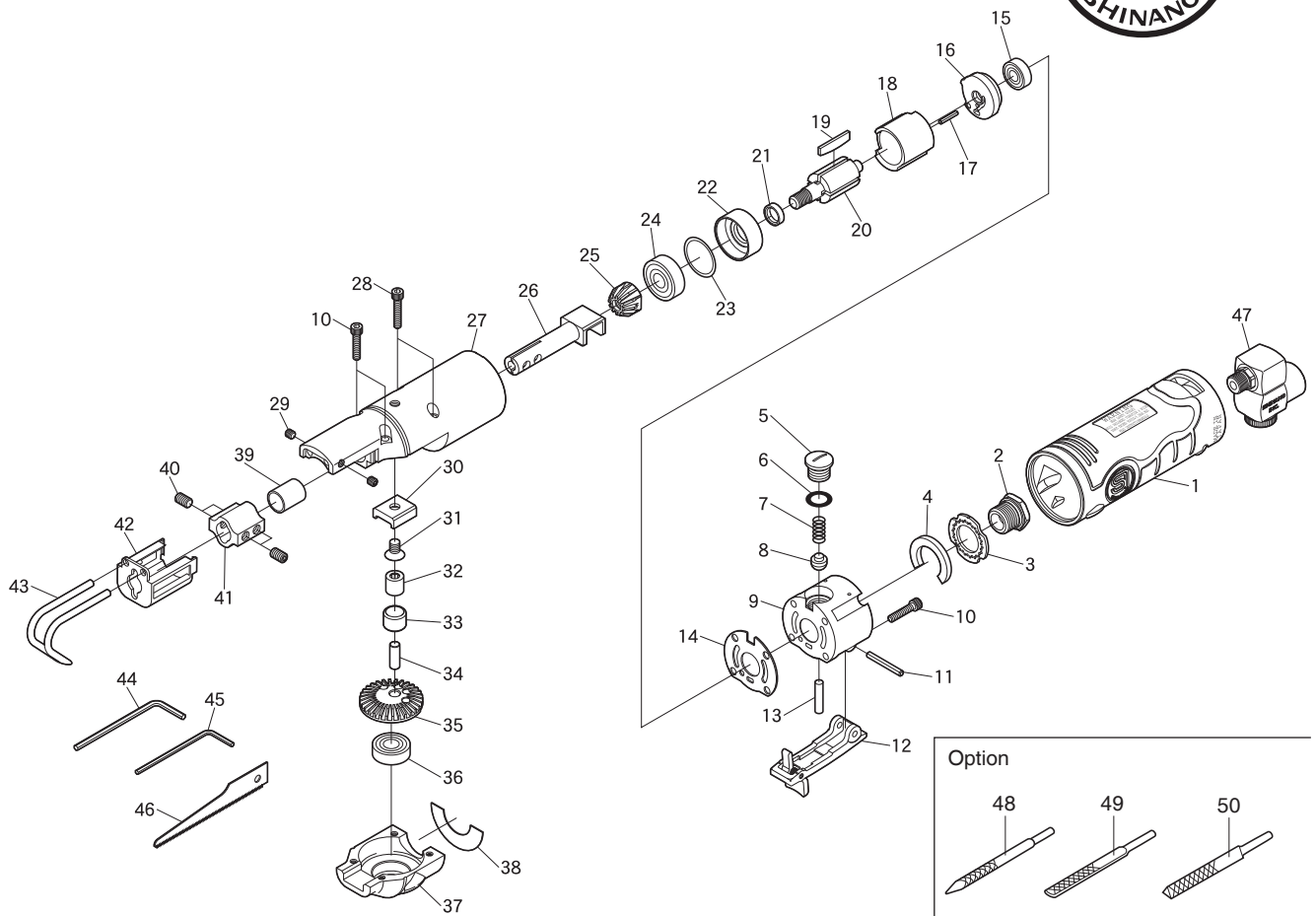

Ref. No.	Parts No.	Description	Q'ty	Ref. No.	Parts No.	Description	Q'ty
1	1026-12	Housing Cover	1	26	1026-5	Slide Pin	1
2	1310-15	Inlet Bushing	1	27	1026-1	Motor Housing	1
3	1026-17	Deflector	1	28	Z-632--185	Cap Screw	2
4	310Q-4	Muffler	1	29	R-M40---40	Set Screw	2
5	800-14	Valve Screw	1	30	1026-10	Slide Guide	1
6	S-9	O-Ring	1	31	E-M50--80	Screw	1
7	670-49	Valve Spring	1	32	HK0509	Needle Bearing	1
8	300-10	Valve	1	33	1026-8	Drive Roller	1
9	1026-15	Valve Block incl. Valve Bush(310-1S)	1	34	1026-9	Drive Pin	1
10	Z-632--165	Cap Screw	6	35	1026-4	Bevel Gear	1
11	30-24	Lever Pin	1	36	698ZZ	Ball Bearing	1
12	1026-16	Throttle Lever	1	37	1026-2	Crank Cover	1
13	310-4S	Valve Pin	1	38	1026-20	Gasket	1
14	1026-14	Gasket	1	39	1026-13	Bush	1
15	696ZZ	Ball Bearing	1	40	R5M50---80	Set Screw	4
16	1313-6	Rear Plate	1	41	1026-18	Blade Chuck	1
17	20-12	Roll Pin(2ø-12mm)	1	42	1026-11	Chuck Cover	1
18	1313-4	Cylinder	1	43	1025-26	Work Guide	1
19	1313-5	Rotor Blade	4	44	WRA-2.5	2.5 mm Allen Wrench	1
20	1026-6	Rotor	1	45	WRA-2	2 mm Allen Wrench	1
21	330-18	Collar	1	46	1026-49ASI	Saw Blade 32T	1
22	1026-7	Front Plate	1	47	1026-50	Swivel Regulator	1
23	330-20	Shim(0.03mm)	1	★ 48	506P-56R	Optional Round File	1
24	608ZZ	Ball Bearing	1	★ 49	506P-56F	Optional Square File	1
25	1026-3	Pinion Gear	1	★ 50	506P-56T	Optional Triangle File	1