

# SI-4800

## Hydro Puncher

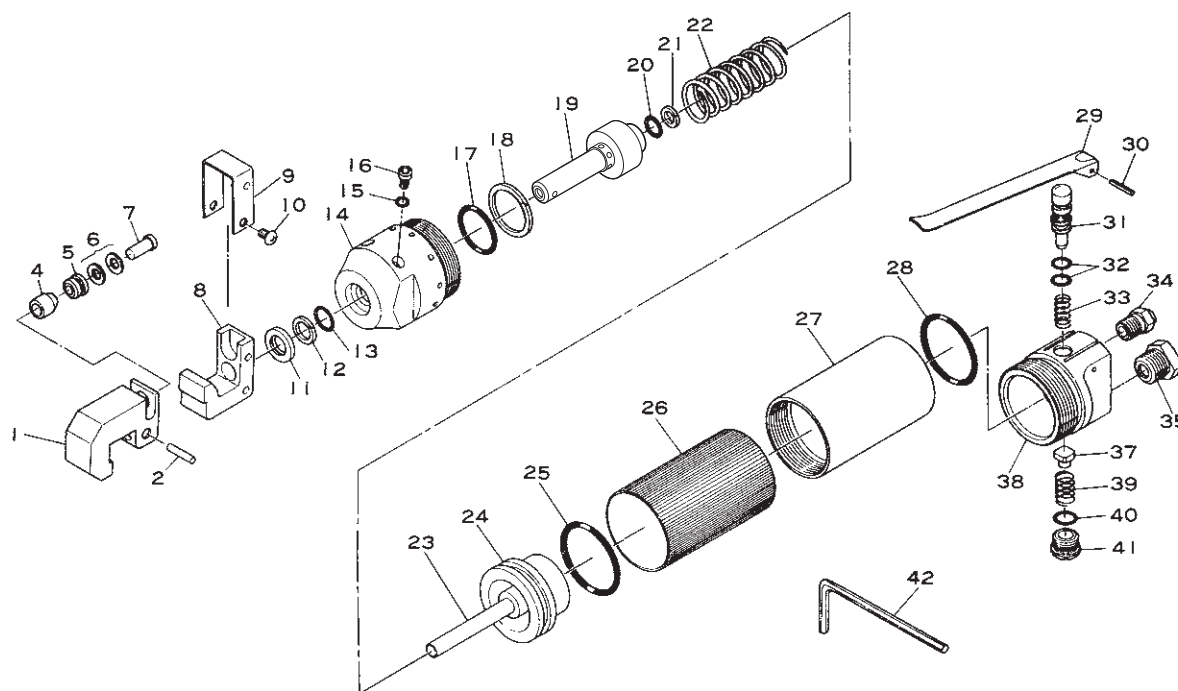

Ref. No.	Parts No.	Description	Q'ty	Ref. No.	Parts No.	Description	Q'ty
1	145-12A	Working Arm	1	23	145-8	Plunger	1
2	230-18	Pin	1	24	145-7	1st Piston	1
4	145-13-5	Die	1	25	P-41	O-Ring	1
5	145-15-5	Guide	1	26	145-39	Rubber Grip	1
6	145-16-5	Cup Spring	11	27	145-2	Cylinder	1
7	145-14-5	Punch	1	28	450-36	O-Ring	1
8	145-11	Rigid Arm	1	29	145-6	Throttle Lever	1
9	145-18	Arm Cover	1	30	30-24	Roll Pin (3-24mm)	1
10	G-M40-60	Screw	2	31	145-4	Valve Stem	1
11	910-17	Oil Seal	1	32	P-7	O-Ring	2
12	BB012	Backup Ring 1	1	33	200-6	Valve Spring	1
13	P-12	O-Ring	1	34	145-41	Exhaust Bushing incl. Screen (610-33)	1
14	145-10	Front Cap	1	35	670-22SC	Inlet Bushing incl. Screen (680-28A) & Retainer (CRTW-12)	1
15	S-6	O-Ring	2				
16	Z-M50-80	Cap Screw	2	37	145-3	Valve	1
17	AS568-215	O-Ring	1	38	145-1	Valve Housing	1
18	145-28	Backup Ring 2	1	39	230-4	Valve Spring	1
19	145-9A	2nd Piston	1	40	P-10	O-Ring	1
20	AS568-109	O-Ring	1	41	230-68	Valve Screw	1
21	145-29	Backup Ring 3	1	42	WRA-4	4mm Allen Wrench	1
22	145-38	Return Spring	1				