

SI-5305A (3/8") / SI-5305-8A (1/2")

INSTRUCTION MANUAL FOR AIR DRILLS

Operation Procedures

1. Connect the coupler to the air inlet ①.
2. The handle position can be changed in the 360 degree range. Determine the handle position according to the operation point.

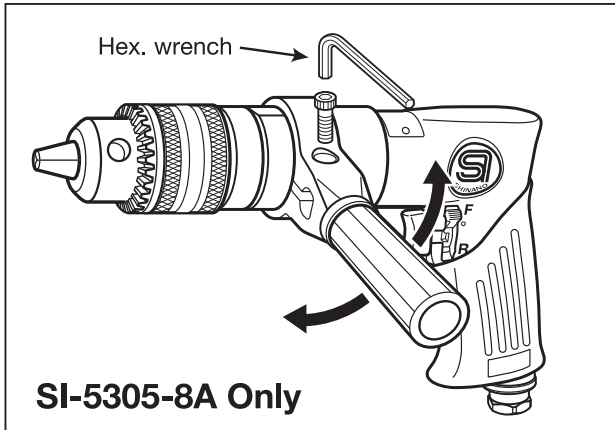

3. Insert a drill bit into the drill chuck, and fasten it with the chuck handle so that claws can evenly bite at three points.

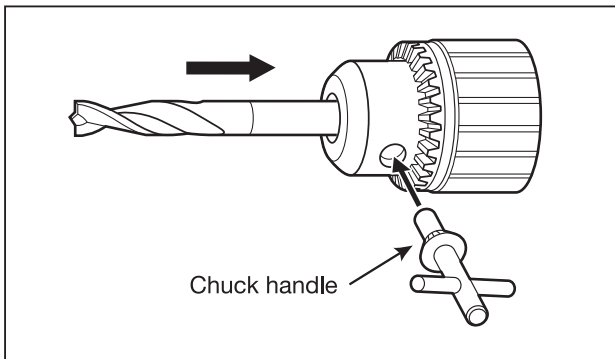

4. Pour approx. 0.5cc (2 to 3 drops) of the oil through the coupler. Connect it to the air hose, and run for 3 to 5 seconds to circulate the oil.

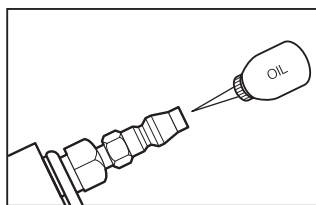

5. Raise the reverse lever, and it will rotate clockwise(right). Lower the reverse lever, and it will counterclockwise (left).

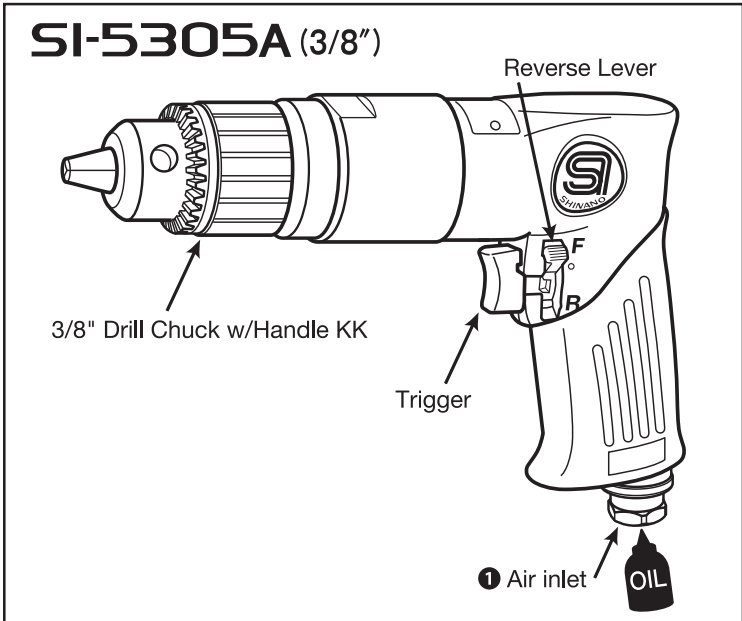
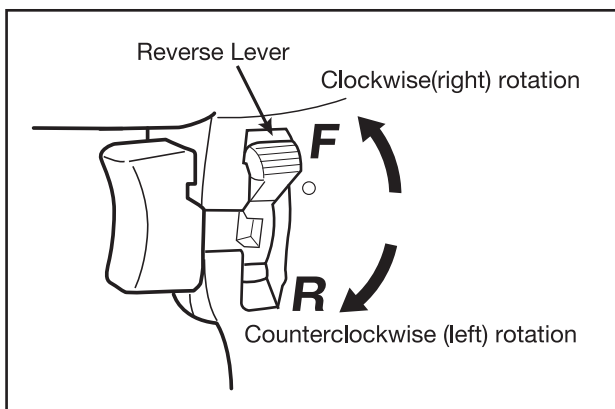

Accessories : 3/8" Drill chuck (1), Chuck Handle (1), Safety instructions (1)

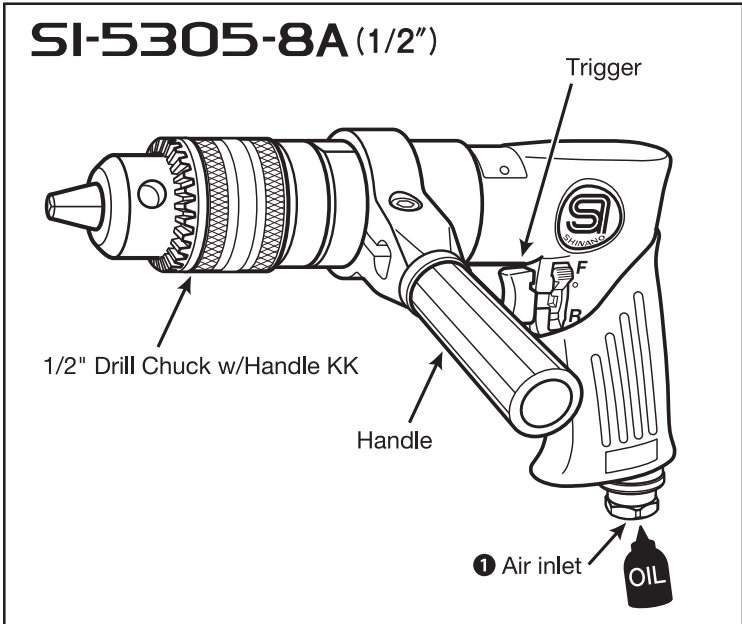

Accessories : 1/2" Drill chuck (1), Chuck Handle (1), Safety instructions (1)

6. Pull the throttle to start the operation, and release it to stop the operation. Fine adjustment can be done by pull variation.

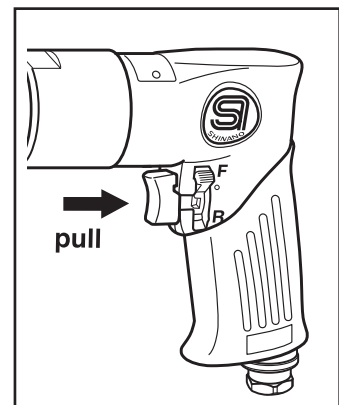

SI-5305A / SI-5305-8A

Model Number	Free Speed rpm	Chuck Size mm/(in.)	Spindle Size	Drilling Cap mm/(in.)	Out Put Watt	Weight kg/(lb)	Noise Level dBA/(power)	Vibration a/k m/s ²	Avg. Air Consumption CFM	Hose Size mm/(in.)
SI-5305A	2,000	10/(3/8)	3/8-24UNC	10/(3/8)	326	1.02/(2.24)	90/(101)	4.7/0.9	3.9	10/(3/8)
SI-5305-8A	800	13/(1/2)	3/8-24UNC	13/(1/2)	326	1.45/(3.20)	91/(102)	6.0/1.6	4.2	10/(3/8)

Noise levels according to ISO 15744:2008, ISO 11203:2009

Vibration level according to ISO 28927:12

WARNING

- Neither use the damaged drill bit nor the different size product.
- When a work with high hardness is drilled, gradually do the initial operation at low speed, because it burdens over the hands.
- Be sure to use the drill bit and the other parts, which we can recommend.

CAUTION

- Avoid using it for the other purpose than the usage, and do the forcible operation beyond the capability.
- Unnecessary idle operation will encourage to wear and result in failure. Avoid such operation.
- The air tool is a precious tool. Neither throw nor drop the tool, nor give a strong shock thereto.
- After operations, be sure to prevent dusts from entering at the air inlet.
- Operate the tool within the air pressure of 0.63Mpa (6.5kg/cm²). If operated in high pressure, the maximum allowance speed will be exceeded, which may result in damage of components.



<http://www.shinanoinc.com>

MADE IN JAPAN