

SI-3101LG (M)

5" Dual Action Sander

SI-3101-6LG (M)

6" Dual Action Sander

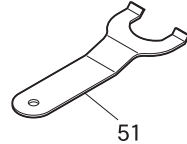
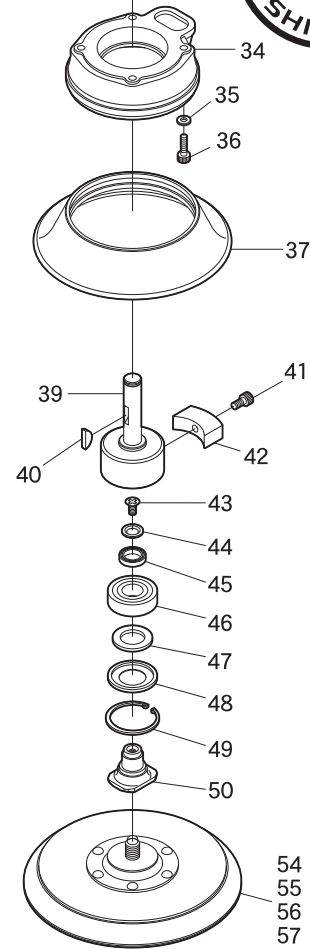
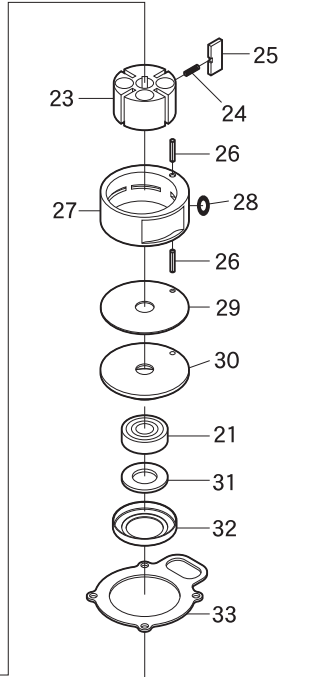
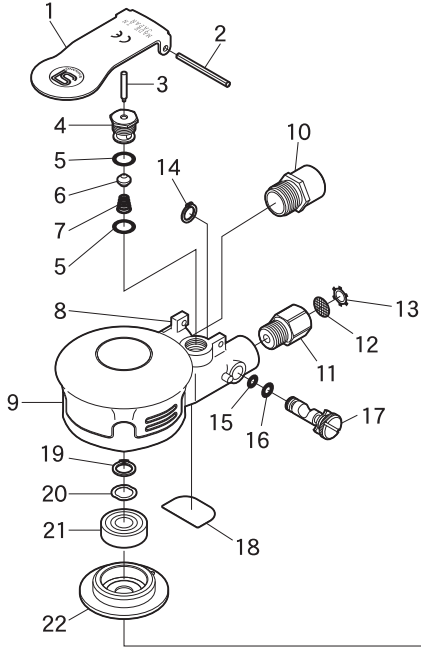

Ref. No.	Parts No.	Description	Q'ty	Ref. No.	Parts No.	Description	Q'ty
1	1040-11B	Throttle Lever	1	29	1040-6C	End Plate	1
2	30-40	Roll Pin(3ø-40mm)	1	30	1040-5	End Plate	1
3	455-11	Valve Pin	1	31	570-1	Felt Ring	1
4	490-4	Valve Body	1	32	481-9	Seal Cover	1
5	S-10	O-Ring	2	33	1040-9	Motor Gasket	1
6	455-21	Valve	1	34	1041-10B	Balancer Cover	1
7	490-20	Valve Spring	1	35	1040-19	Washer	4
8	1040-1	Motor Housing	1	36	Z-632--127	Cap Screw	4
9	1044-1A	Housing Cover	1	37	1044-2	Pad Cover	1
10	1040-18AS	Muffler Assy.	1	39	1044-4	Balancer Shaft	1
11	180-1	Inlet Bushing	1	40	480-23	Key	1
12	680-28A	Screen	1	41	Z-M40---80	Cap Screw	1
13	CRTW-12	Retainer	1	42	1044-3	Balancer	1
14	JS-8	Retaining Ring	1	43	E-M40---80	Screw	1
15	P-4	O-Ring	1	44	1044-6	Washer	1
16	P-5	O-Ring	1	45	1040-24	Collar	1
17	485-4	Air Regulator	1	46	6001DDW	Ball Bearing	1
18	1040-50	Cover Plate	1	47	1041-50	Felt	1
19	JS-10	Retaining Ring	1	48	1041-51	Seal Plate	1
20	WW-100	Wave Washer	1	49	BO-28	Retaining Ring	1
21	6000-ZZ	Ball Bearing	2	50	1044-5	Random Shaft	1
22	1040-5C	Baearing Case C	1	51	1041-56	Spanner Wrench	1
23	1040-4	Rotor	1	★ 54	M-150H	6" Velcro Pad	1
24	490-1	Blade Spring	2	★ 55	P-150H	6" Leather Pad	1
25	1040-17	Rotor Blade	4	☆ 56	M-125H	5" Velcro Pad	1
26	25-14	Roll Pin(2.5ø-14mm)	2	☆ 57	P-125H	5" Leather Pad	1
27	1040-2	Cylinder	1				
28	P-7	O-Ring	1				