

## INSTRUCTION MANUAL FOR DOUBLE ACTION SANDERS

### Operation Procedures

1. Connect the coupler to the air inlet ❶ on the rear side of the tool.
  - In case of SI-3114 (dust free type), the dust hose equipped with the dust pack should be securely covered over the exhaust port ❷.
2. Make sure the pad should be securely mounted, and attach the paper thereto.
  - In case of SI-3114 (dust free type), the paper hole should be fit to the pad dust vacuum hole, and securely patched thereto.
3. Pour approx. 0.5cc (2 to 3 drops) of the oil through the coupler. Connect it to the air hose, and run for 3 to 5 seconds to circulate the oil.
4. Adjust revolutions per minute with the air regulator ❸. The maximum speed should be 10,000 revolutions per minute (0.63MPa).

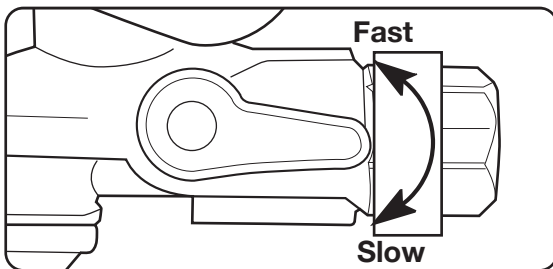

5. Press the throttle lever ❹ for operation, and release it for stop.

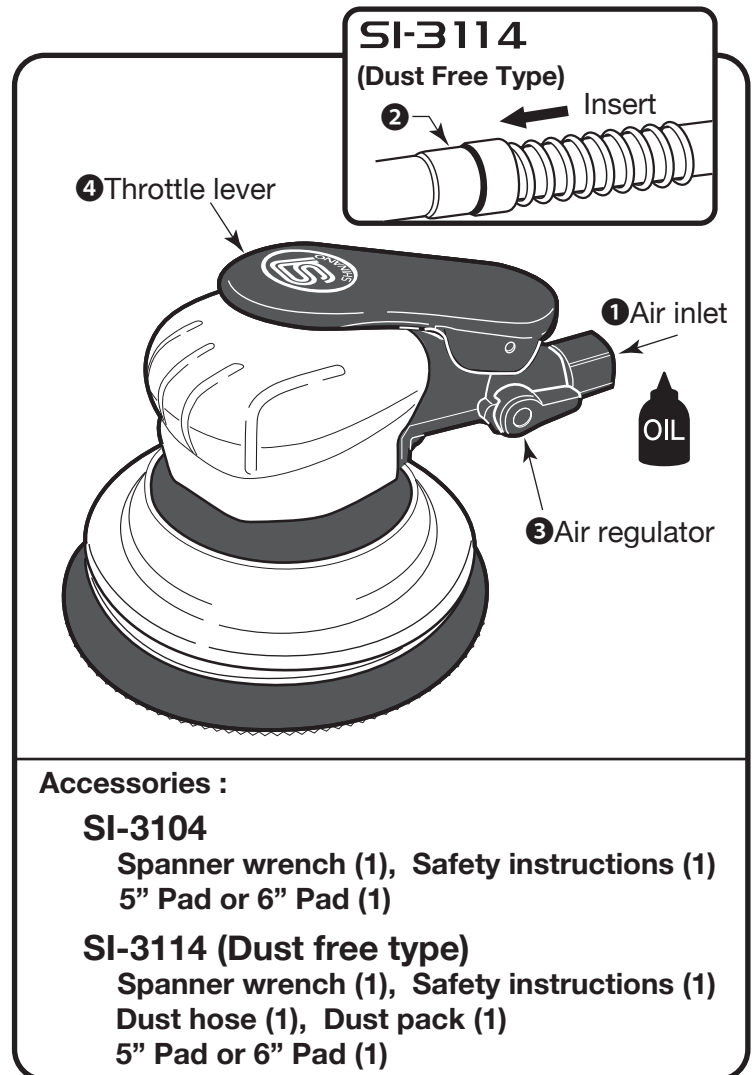

### Replacement of Pad

- The nut should be nipped and fixed with the service wrench.

**Pad mounted :**  
clockwise (right direction)

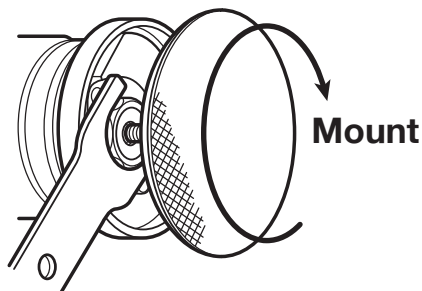

**Pad dismantled :**  
counterclockwise (left direction)

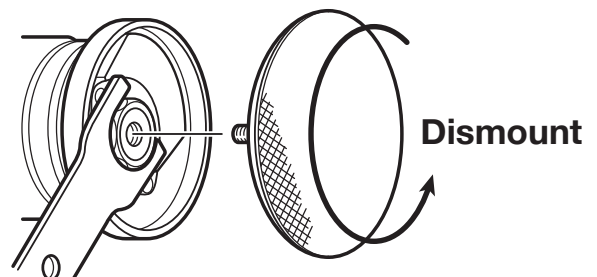

- Our original pad should be surely employed.

## SI-3104, SI-3104-6 / SI-3114, SI-3114-6

Model Number	Pad/Disc Size mm/(in.)	Spindle Size Female	Orbit Dia mm	Free Speed rpm	Out Put Watt	Weight kg/(lb)	Noise Level dBA/(power)	Vibration a/k m/s <sup>2</sup>	Avg. Air Consumption CFM	Air Inlet Size in.	Hose Size mm/(in.)
<b>SI-3104</b>	125/(5")	5/16-24UNF	5	10,000	188	0.87/ (1.92)	82/ (93)	7.3/(3.3)	15.9/7.5	1/4	10/(3/8)
<b>SI-3104-6</b>	150/(6")	5/16-24UNF	5	10,000	188	0.89/ (1.96)	83/ (94)	5.4/(2.5)	15.9/7.5	1/4	10/(3/8)
<b>SI-3114</b>	125/(5")	5/16-24UNF	5	10,000	188	1.22/ (2.69)	82/ (93)	4.0/(1.1)	13.0/6.1	1/4	10/(3/8)
<b>SI-3114-6</b>	150/(6")	5/16-24UNF	5	10,000	188	1.24/ (2.73)	82/ (93)	3.2/(0.8)	13.0/6.1	1/4	10/(3/8)

Noise levels according to ISO 15744:2008,ISO 11203:2009 Vibration level according to ISO 28927:3

### WARNING

- For replacement of pad and paper, be sure to dismount the air hose.
- Be sure to mount the pad firmly and completely.
- Never use the grinding stone for this tool.
- Be sure to remove the service wrench used for replacement of pad.
- Vibration will be felt. Avoid continuous operation if possible. Do operations at the rest interval of approx. 10 minutes per an hour.

### CAUTION

- If operations proceed using the whole edge or the part of the pad, the pad will be damaged, which loses tool balance, and prevents exact grinding. Be careful not to do such wrong operations.
- Careless drop of the tool will result in damage of the tool or components. Therefore, be sure to politely handle the tool.
- Operate the tool within the air pressure of 0.63MPa (6.5kg/cm<sup>2</sup>). If operated in high pressure, the maximum allowance speed will be exceeded, which may result in damage of components.
- Before or after daily use, lubricate a few drops of air tool oil from the hose attached port.
- The compressed air containing dust or/and moisture will result in damage of tool. Be sure to operate the tool with air through the drainage and air filter.
- If revolution failure or/and irregular noise occurred, do not continue operation furthermore. Forced operation of tool may result in serious troubles.
- Regarding to this product, if inconvenient claims or troubles occurred, contact the product distributor.

### AIR SUPPLY

Pressure at the working	<b>0.63MPa (90PSI 6.3bar)</b>
Max Hose Length	<b>10m (30ft)</b>
Lubrication	<b>Daily Lubricating oil</b>

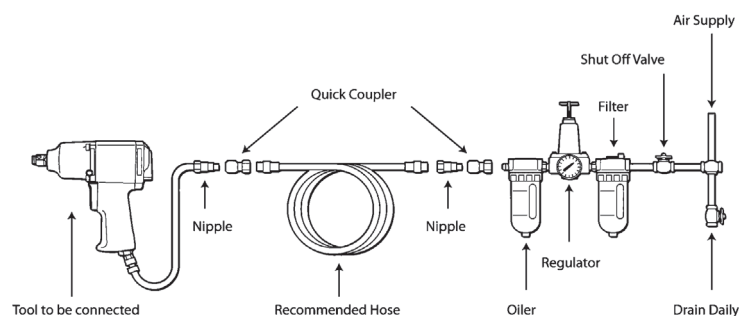

 **SHINANO INC.**  
<https://www.shinanoinc.com>

MADE IN JAPAN